

# Brio Weatherfold 4s 50 & 100

Brio Australia  
 P: +61 2 87186718  
 W: [brio.com.au](http://brio.com.au)  
 E: sales@brio.com.au

Brio RMD UK Ltd.  
 P: +44 191 2291224  
 W: [briouk.com](http://briouk.com)  
 E: sales@briouk.com

Brio USA Inc.  
 P: +1 585 3195599  
 W: [briouusa.com](http://briouusa.com)  
 E: sales@briouusa.com

## Codes

**B WS 1 - 50 S H PB**

Finish: PB (Physical Vapour Deposition Brass), PR (Physical Vapour Deposition Black), SS (Satin Stainless), PS (Polished Stainless)  
 Hinge Type: See section Hinge Installation (page 5)  
 Bearing Type: S (Stainless Steel Bearing), C (Chrome Steel Bearing)  
 Load Capacity: 50kg (110lbs) and 100kg (220lbs) panels  
 Set No.: 1 (Pivot Set), 2 (End Hanger Set), 4 (Intermediate Hanger Set), 3 (Hinge Handle Set), 5 (Hinge Set), 6 (Offset Hinge Set), 7 (Offset Hinge Handle Set), 8 (Meeting Rebate Door Set)

## Brio Weatherfold 4s

**Sets** all sets shown with hinge type H except BWS8. BWS8 sets available in 100. No finishes shown.

BWS1-100H

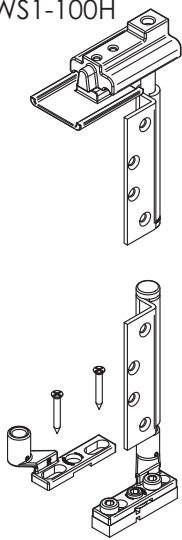

BWS2-50SH  
BWS2-50CH

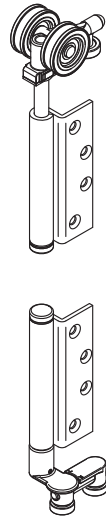

BWS2-100SH  
BWS2-100CH

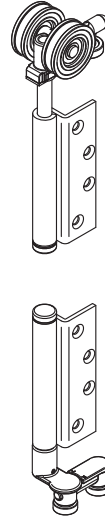

BWS8-50S  
BWS8-50C

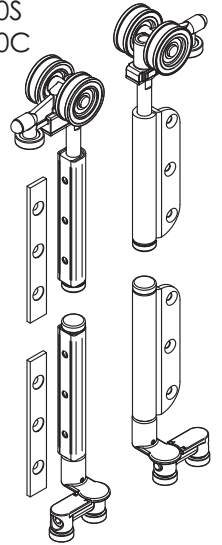

BW3-100H

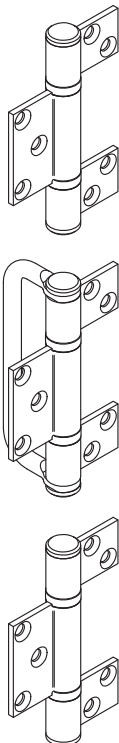

BW5-100H

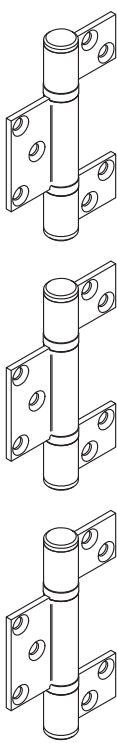

BW6-100H

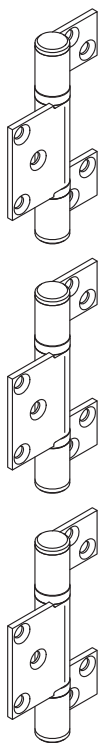

BW7-100H

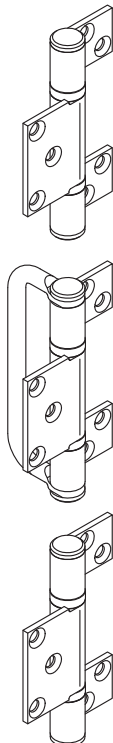

BWS4-50SH  
BWS4-50CH

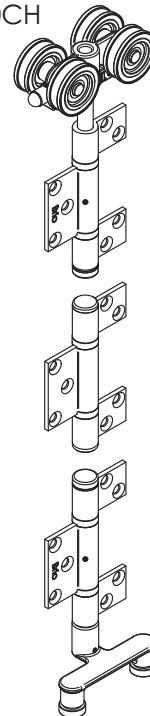

BWS4-100SH  
BWS4-100CH

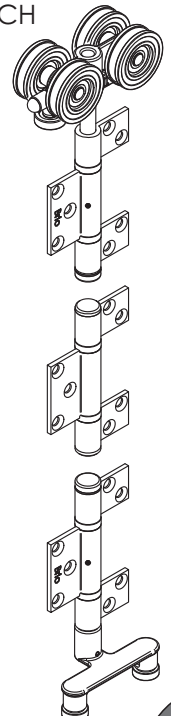

# Door Hardware Set Orientation

FB = Flush Bolt, FP = Flush Pull, LK = Lock, left systems shown

## OUTWARD OPENING

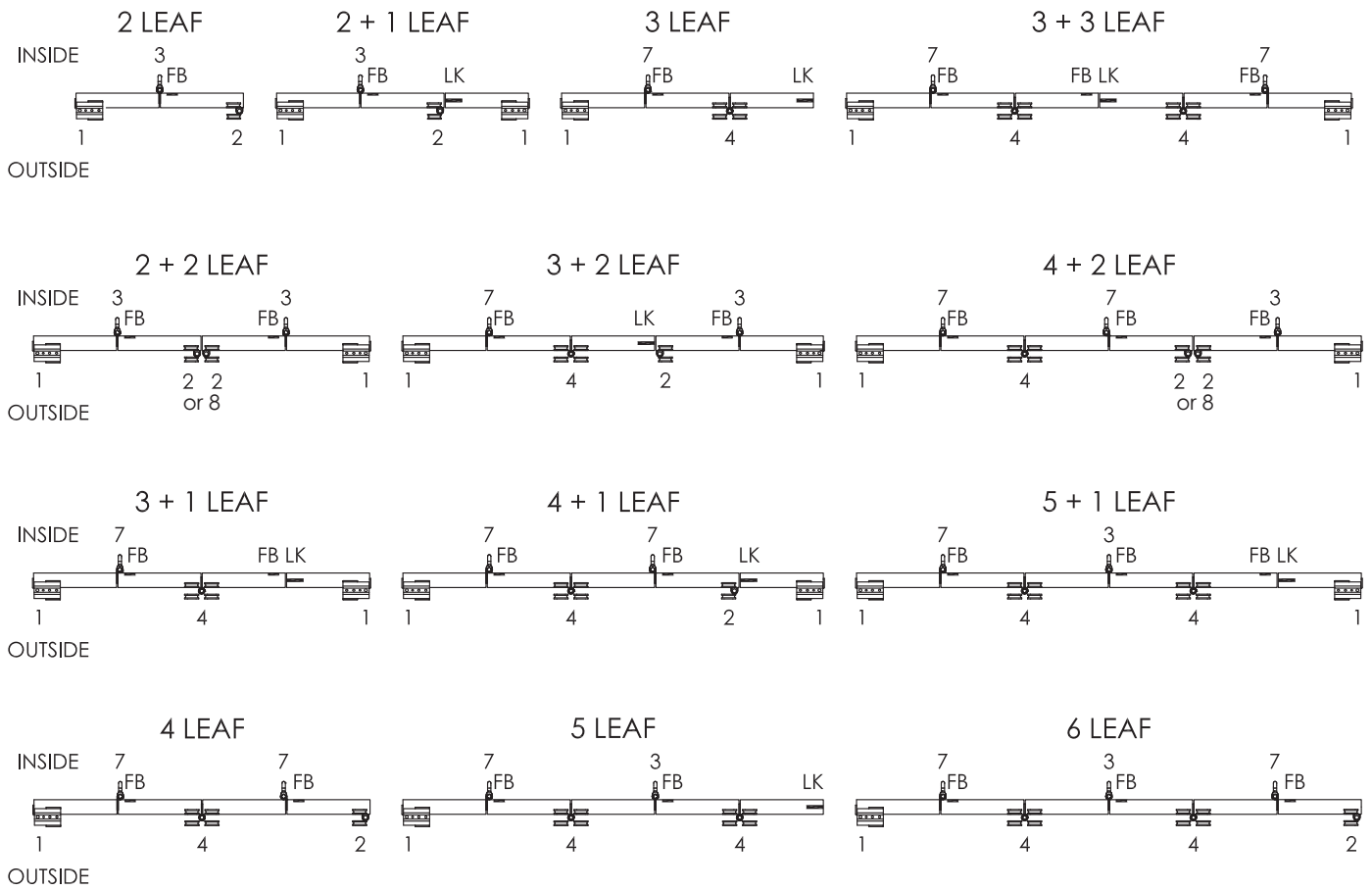

## INWARD OPENING

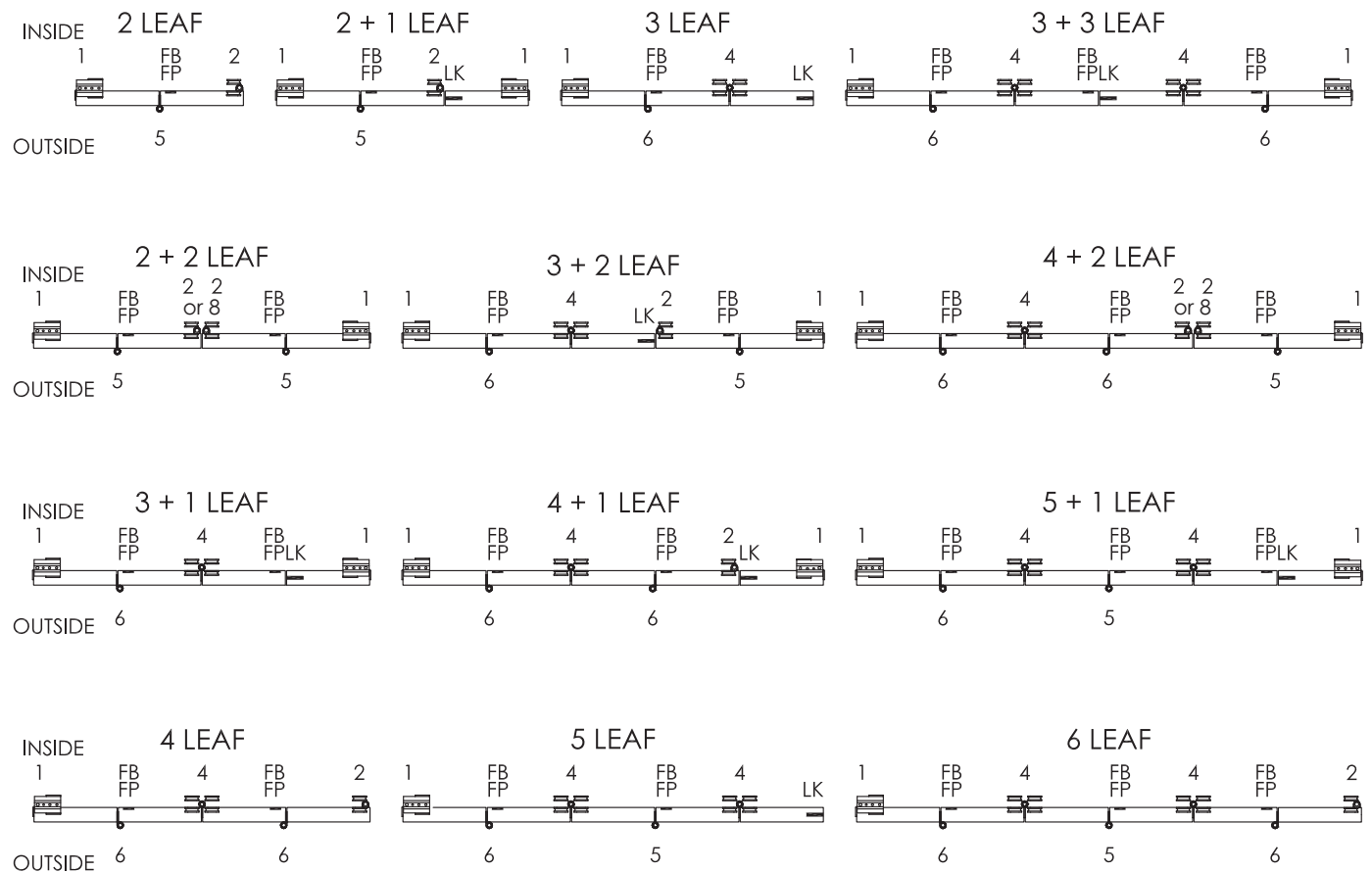

# Opening Preparation outward opening system shown, dimensions shown in mm[inches]

180 Track for 50kg(110lbs)  
250 Track for 75kg(165lbs) & 100kg(220lbs)

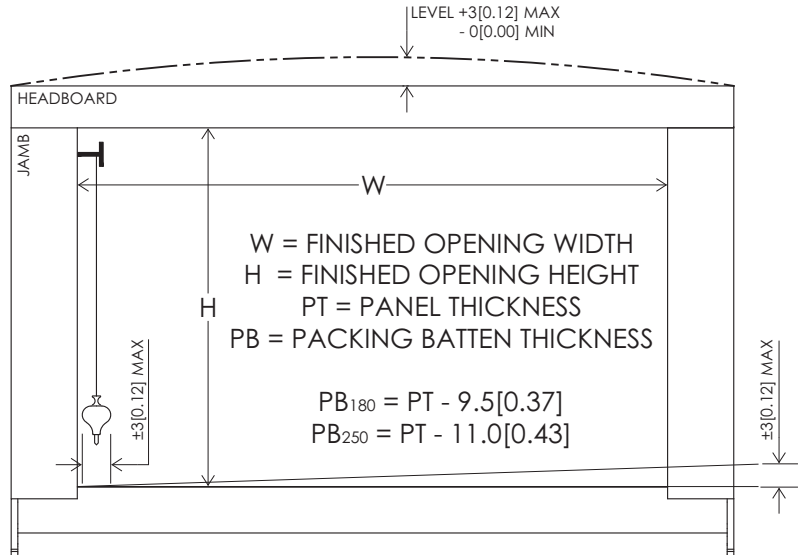
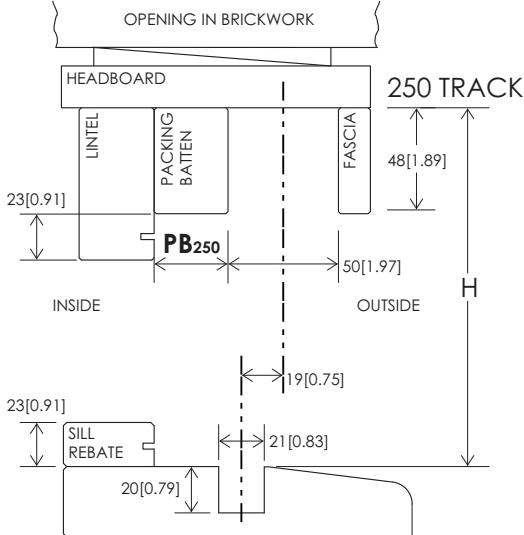
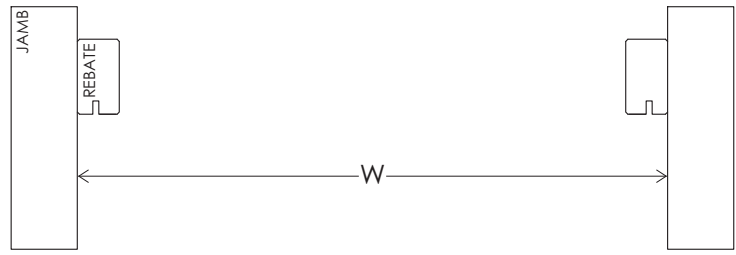
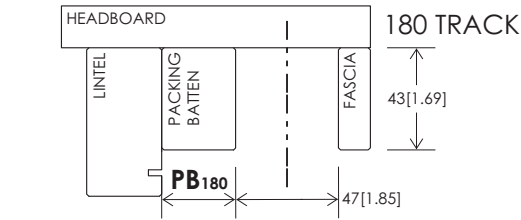

## Track Preparation track and channel cut to length 'W' (finished opening width)

OPTION A - Allows access to hangers through notch in track

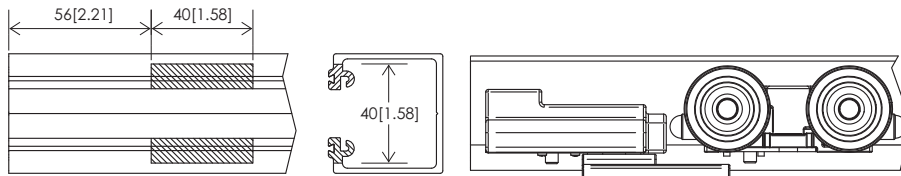

Clamp plate covers notch in track

OPTION B - Allows access to hangers by removing track section

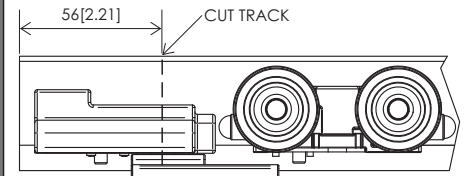

## Install Track & Channel

Insert Polypile

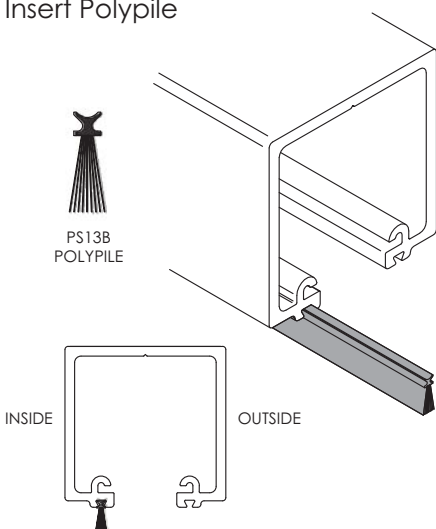

Install polypile on inside of system

Fix track with 10G screws. After initial 6 fixings, fix screws at 400 [15.75] intervals. Secure polypropylene channel with adhesive.

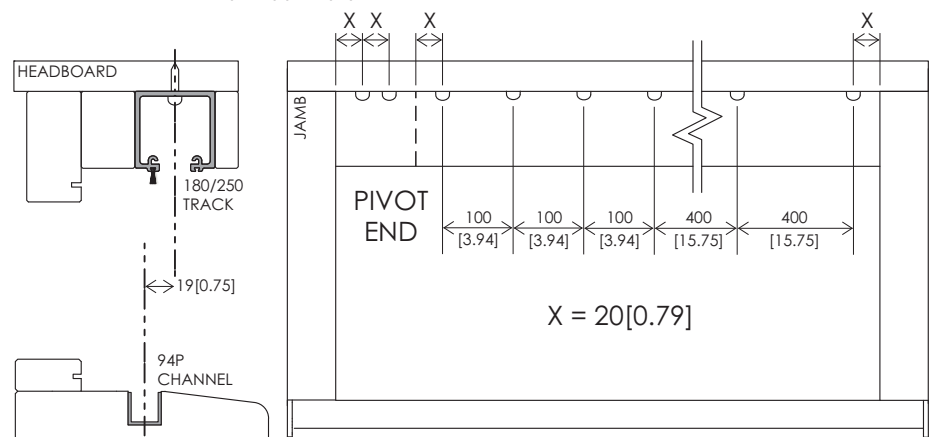

If installing 94PA, recess into sill 23 [0.91] deep by 25 [0.95] wide then countersink and screw fix at 400 [15.75] intervals. Install 94P last.

# Panel Size Calculation free leaf width calculator available from Brio (includes BOM & pricing)

Brio Weatherfold 4s allows for equal size panels

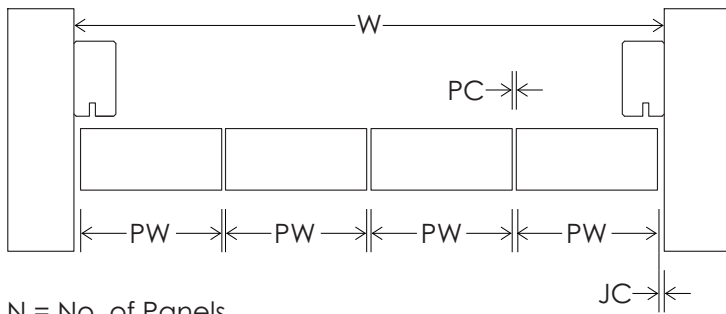

N = No. of Panels  
 PW = Panel Width  
 JC = Jamb Clearance = 6[0.24]  
 PC = Panel Clearance = 4[0.16]

$$PW = \frac{W - [PC(N-1) + 2(JC)]}{N}$$

PH = Panel Height

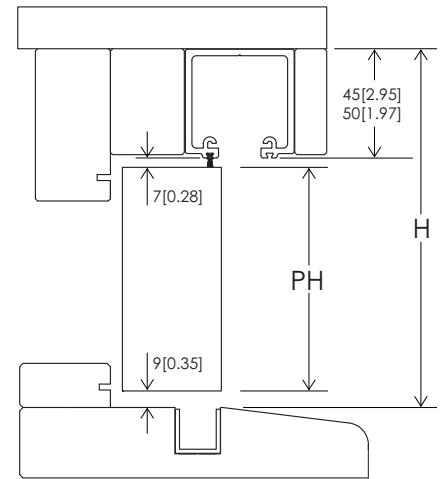

$$PH_{180 \text{ TRACK}} = H - 61[2.40]$$

$$PH_{250 \text{ TRACK}} = H - 66[2.60]$$

## Seal Preparation left, outward opening system shown

Frame - AQ21 perimeter seals to butt against each other in all corners

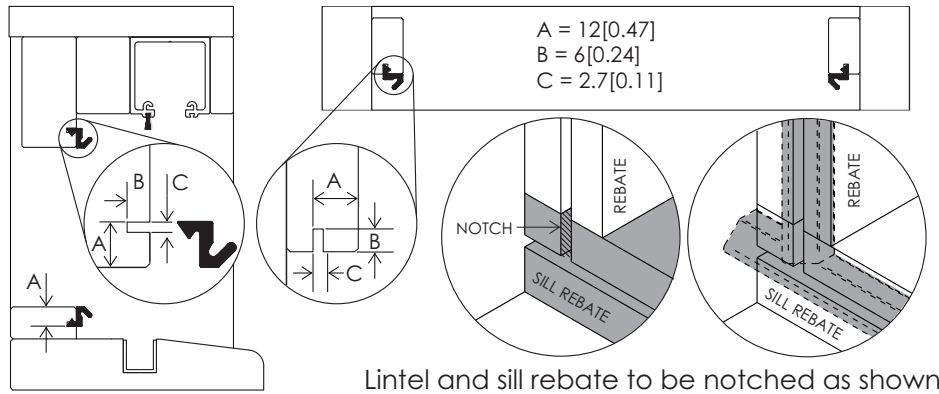

Lintel and sill rebate to be notched as shown

Panel - AQ63

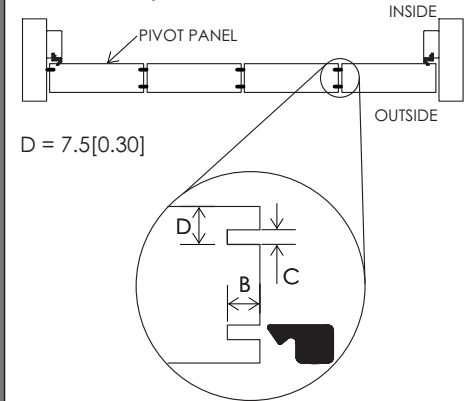

## Meeting Door Selection

2 Meeting square doors

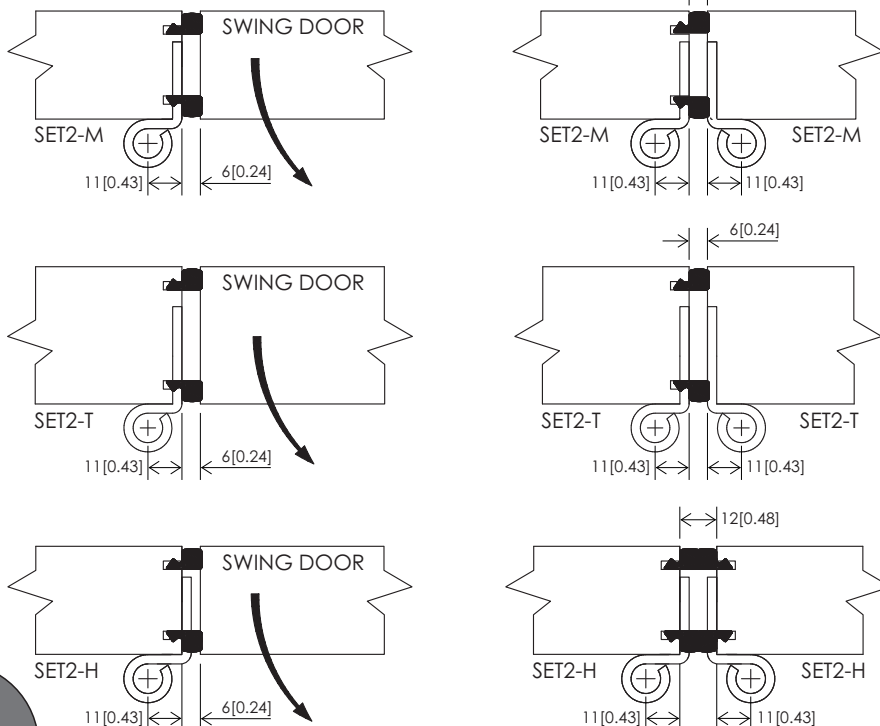

2 Meeting rebate doors

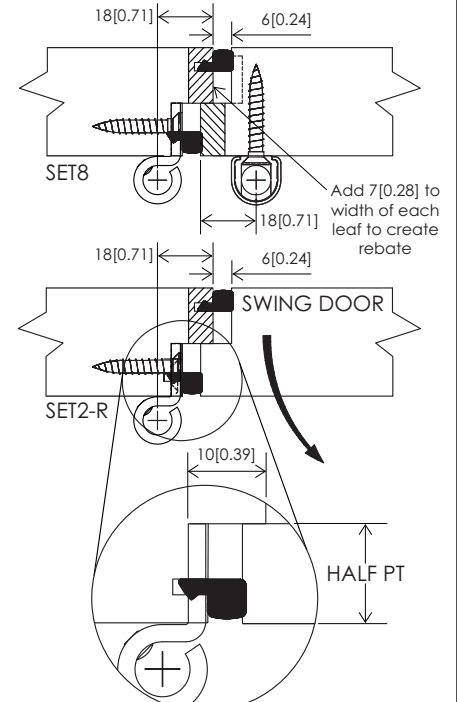

For more rebate detail contact Brio

# Hinge Installation

pilot hole of  $\varnothing 2.5\text{mm}$ [0.12"] recommended

## Non-mortise H 35[1.38]-68[2.68] Panel Thickness

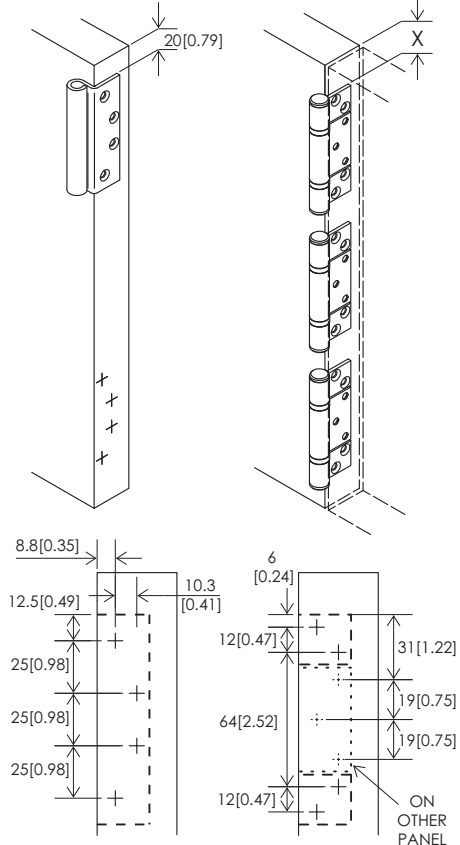

X=20[0.79] on Set 4  
 X=60[2.36] min on Sets 3, 5, 6 & 7  
 Drilling jig available for H Sets

## Mortise Radius Corner T 44[1.73]-68[2.68] Panel Thickness

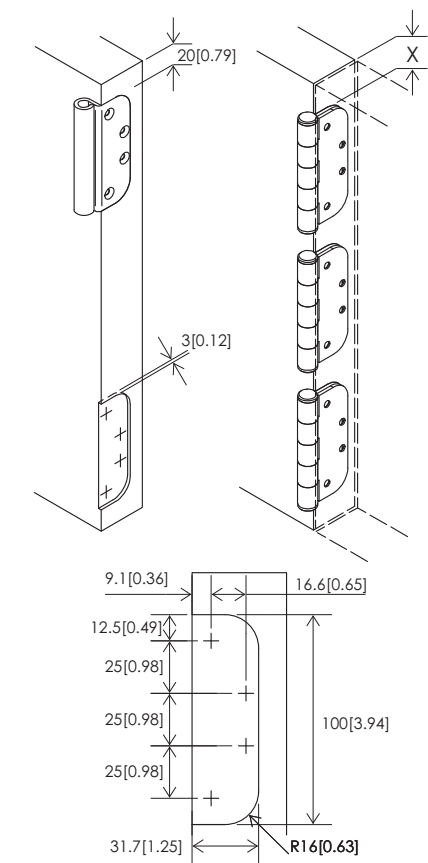

X=20[0.79] on Set 4  
 X=60[2.36] min on Sets 3, 5, 6 & 7

## Mortise Square Corner M 35[1.38]-68[2.68] Panel Thickness

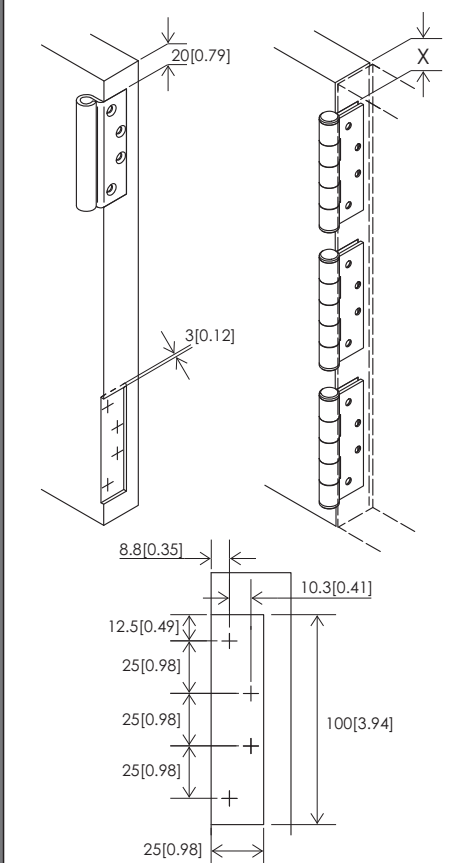

X=20[0.79] on Set 4  
 X=60[2.36] min on Sets 3, 5, 6 & 7

## Face Fix F

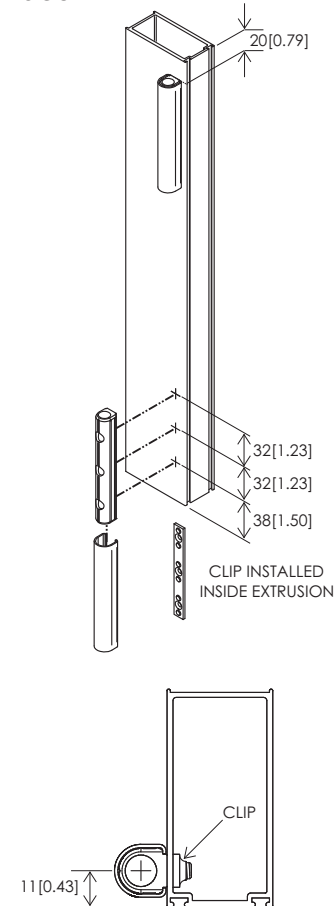

Drill holes  $\varnothing 5$ [0.20]

## Rebate R

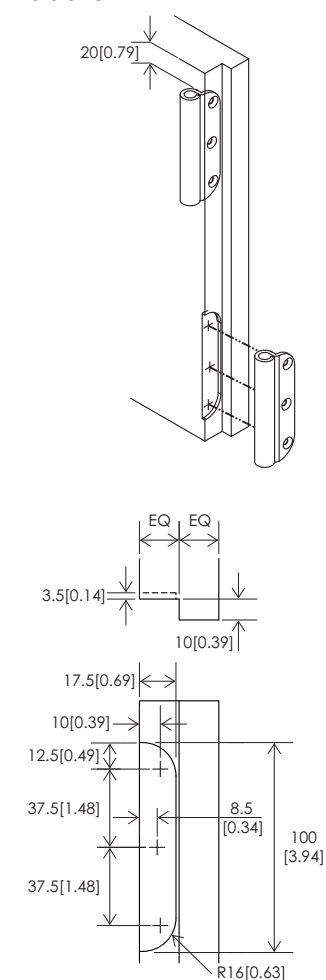

## Meeting Rebate Door Set 8

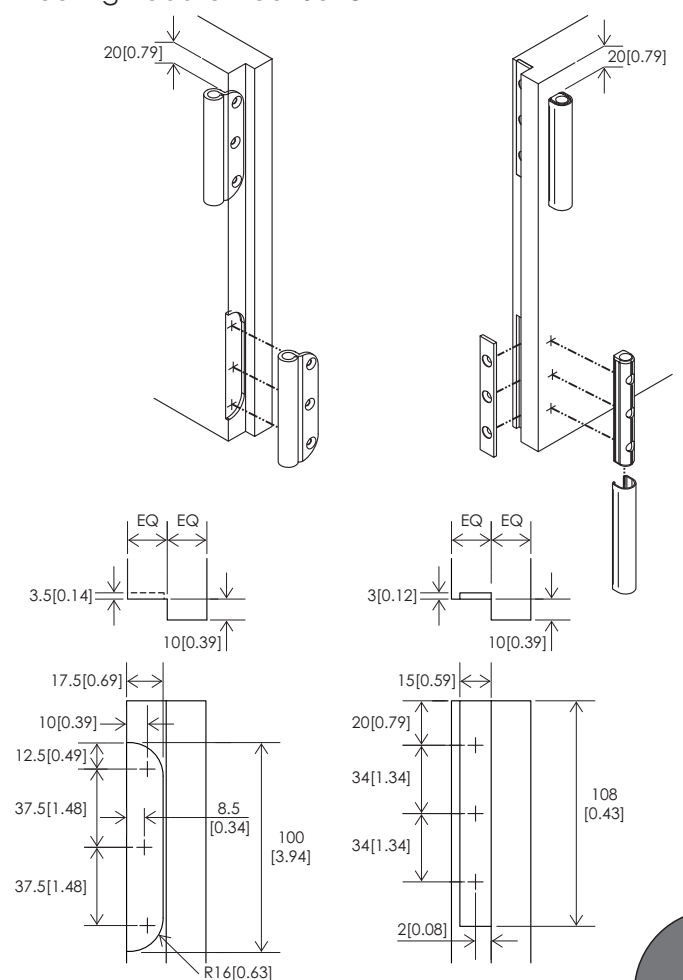

# Flush bolt Position

see page 2 for flush bolt location for all configurations, router available

### Install flush bolt to panel

PANEL	FLUSH BOLT
PH ≤ 2200 [86.6]	456R
2200 [86.6] ≤ PH ≤ 2440 [96.1]	456RL
2440 [96.1] ≤ PH ≤ 2740 [107.9]	456RLX-600
2740 [107.9] ≤ PH ≤ 3300 [129.9]	456RLX-1000

FLUSH BOLT	X
456R	190 [7.48]
456RL	450 [17.72]
456RLX-600	600 [23.62]
456RLX-1000	1000 [39.37]

For square flush bolts  
chisel out corners

Counter bore  
for lockable  
flush bolts

### Install flush bolt keeper to sill

PIVOT PANEL  
FLUSH BOLT  
INSIDE  
OUTSIDE  
KEEPER  
DUST BOX  
8 [0.32]  
30 [1.81]  
Mark where flush bolt throw strikes and notch out hollow for dust box

Extended keeper available

# Optional Security Aligner 199SS

aligns panel to seal perimeter, secures against lifting

### Installation

PIVOT PANEL  
END PANEL  
JAMB  
PANEL CENTRE  
42 [1.65]  
65 [2.56]  
6 [0.24]  
29 [1.14]

JAMB MOUNT  
SOCKET  
PIVOT PANEL  
REBATE  
6 [0.24]  
PT  
28 [1.10]  
25 [0.98]  
EQ EQ  
ROUTE DETAIL  
X = 1/2 (PT) + 6 [0.24]

Can be installed on either pivot or end panel, Minimum PT = 38 [1.50]

### Adjustment

JAMB MOUNT NOSE

Wind nose of jamb mount away from jamb until panel is pulled in to seal perimeter when closed

# Optional Jamb Pivot BW189H

non mortice type H shown but all hinge types available

### Installation

PIVOT PANEL  
END PANEL  
JAMB  
HINGE  
28 [1.10]  
11.5 [0.45]  
6.5 [0.26]  
Ø12 [0.47]  
6 [0.24]  
PIVOT PANEL  
REBATE  
6 [0.24]  
PT  
8 [0.32]  
X = PT + 14 [0.55]

Hinge assembly aligned with other centre hinges

JAMB MOUNT  
PIVOT PANEL

### Adjustment

JAMB PIVOT BOLT

Wind jamb pivot bolt in or out until it aligns with hinge on panel after top and bottom pivot are set

# End Guide

when viewed from outside doors folding left need a left end guide and vice versa for right

### Handing End Guide

Back off cap screw and rotate guide arm into left or right position

### Determining System Orientation

Left, outward opening system

Right, outward opening system

### Handing end set hinge

For Right: Flip hinge

ANTI-SHAKE SET/GRUB SCREW

Lock off anti-shake set/grub screw

# Bottom Pivot

when viewed from outside doors folding left need a left pivot and vice versa for right

### Handing Bottom Pivot

For Right: Interchange pivot arm

LEFT

RIGHT

Flip base over

Secure assembly by locking off cap screws

### Handing pivot set hinge

Push in cap

For Right: Flip hinge

ANTI-SHAKE SET/GRUB SCREW

LEFT

RIGHT

Lock off anti-shake set/grub screw

# System Security

type H hinge shown but security set/grub screw applicable in hinge types T and M too

### Hanger security

SET/GRUB SCREW POSITION ON END SET & PIVOT HINGES

HEX DRIVE

ANTI-SHAKE SET/GRUB SCREW

HINGE PIN

Anti-shake set/grub screw prevents pin being removed from hinge

### Guide security

ANTI-SHAKE SET/GRUB SCREW

ANTI-SHAKE SET/GRUB SCREW

Lock off both set/grub screws

# Attaching Hardware to Panels recommended before installation

Ensure doors are level and square from top

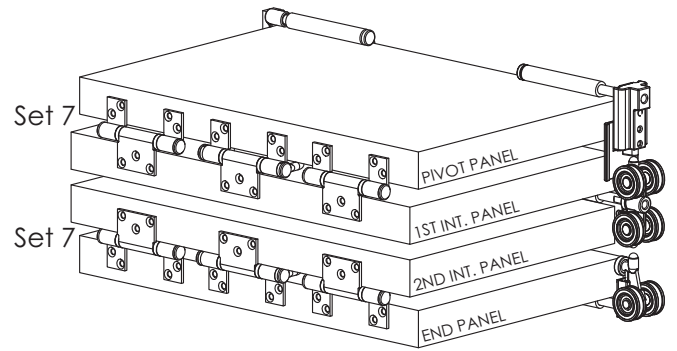
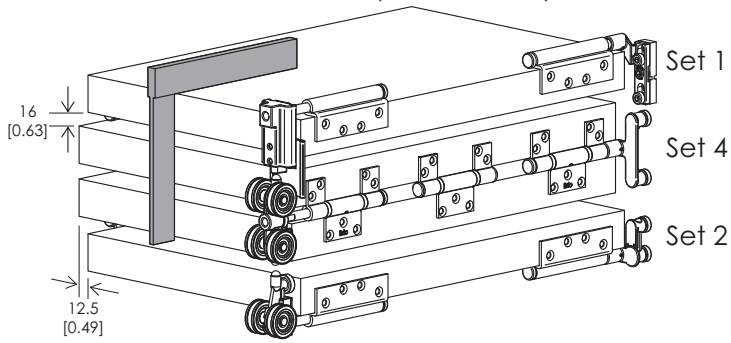

# Installing Hardware and Hanging Panels clean down inside of track and channel

Viewed from outside, insert rollers through access notch in correct order

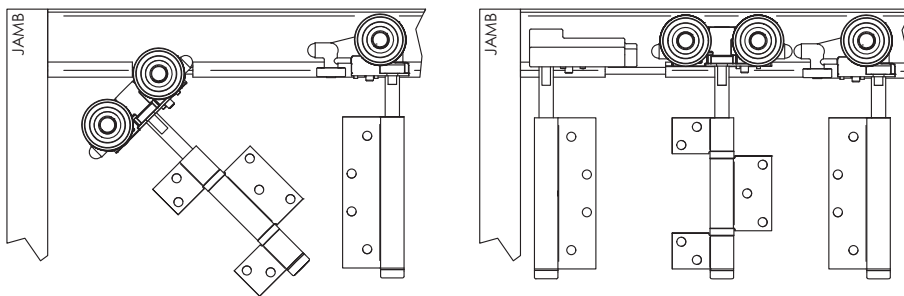

Lock top pivot into position

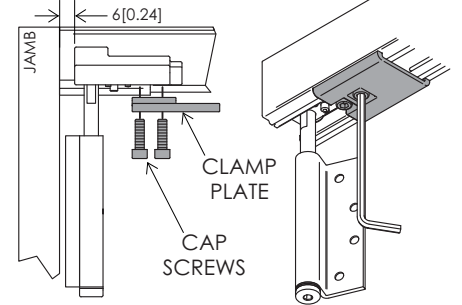

Place bottom pivot in polypropylene channel

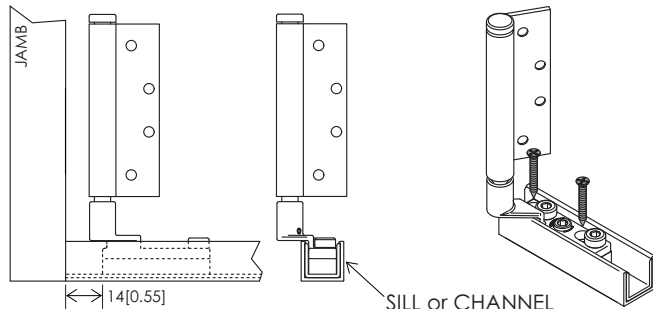

Screw fixings pass through assembly

When cap screws loose, pivot arm can slide freely

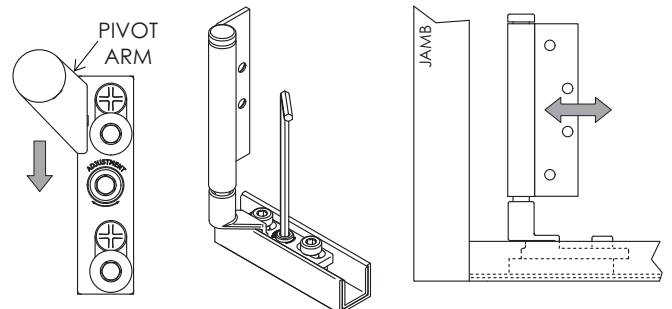

Securely assemble bottom pivot for installation

Bring pivot panel to pivot set

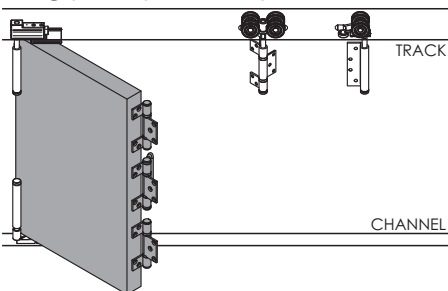

Hinge set 7 attached to panel

Bring 1st int. panel to pivot panel

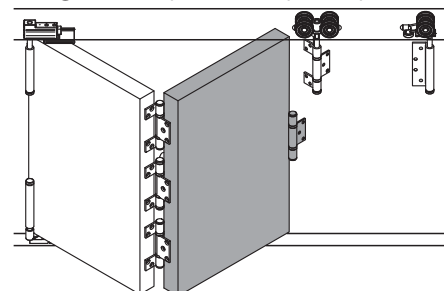

Middle hinge of int. set attached

Fix int. hanger to int. panel

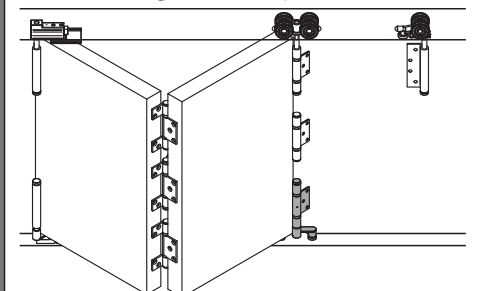

Attach int. guide to int. panel

Bring 2nd int. panel to the int. hanger with hinge set 7

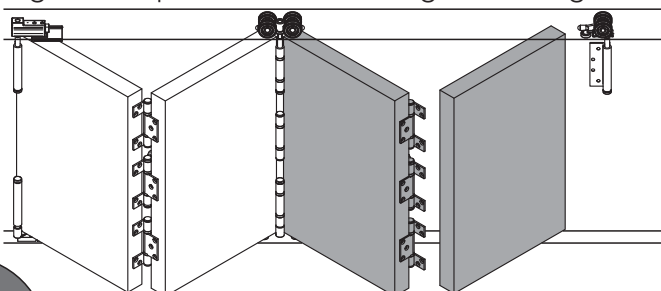

Bring end panel to hinge set 7

Fix end panel to end hanger

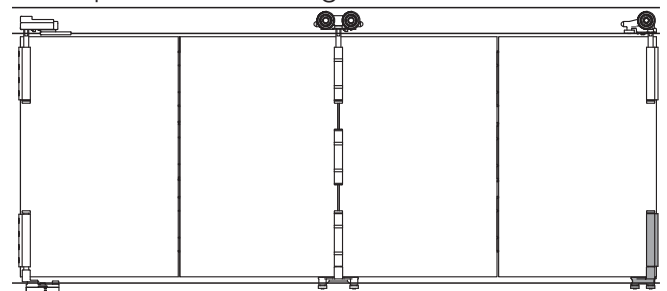

Attach end guide to end panel, close all panels

# Installation when using F hinge types or Set 8

<p>Hinges &amp; pins remain on end panel</p>	<p>Push fit plastic jig onto end hanger and insert into track</p> <p>Jig keeps hanger stable and static</p>	<p>Bring end panel to system</p> <p>Align hanger pin with end hanger and rest panel on blocks in position</p>
<p>Depress button (see adjustment below) engage bolt into hanger</p>	<p>Attach guide to bottom hinge pin</p>	<p>Close all panels</p> <p>Remove jig from hanger</p>

## Adjustment hinge pin locking mechanism applied to all hangers and top pivot

<p>Push in spring loaded button</p> <p>Wind pin into hanger - hanger automatically locks off on bolt flats</p>	<p>Loosen bottom pivot cap screws</p> <p>Adjust all hangers and top pivot until panels are level with track</p>	<p>Once panels are level, partially open doors - lock off 1st cap screw</p> <p>Viewed from inside</p> <p>Open fully, lock off 2nd cap screw</p>
--	---	---

## System Overview

The diagram illustrates the complete door system, showing the internal hinge mechanism and the external track and channel components. The side view shows the door panels, hinges, and the track system. The perspective view shows the door panels in an open position, highlighting the track and channel components.

# Care and Maintenance

Hardware is subject to deterioration from everyday use and from the environment that it is in. In particular, it is important that routine maintenance be carried out in harsh coastal or marine environments and industrial applications.

## General

Inspect all fixing bolts for tightness every six months, including those securing brackets. Tighten if necessary. Routinely check for wear and if excessively worn, the part should be replaced.

To help prevent surface corrosion, Brio® recommends washing regularly; even stainless steel finishes in coastal environments may show signs of surface corrosion if not washed regularly. Sheltered areas that are not rain washed are particularly susceptible. Wash with soap or mild detergent and warm water followed by rinsing with clean cold water and wipe dry.

As a guide, if a window or door requires washing then wash the hardware, however Brio® recommend for marine and industrial environments washing a minimum of every 3 months and 6 months for general environments. In coastal or marine environments Brio® recommends applying a light application of corrosion preventative such as CRC Marine 66 or Inox® for Marine, to all surfaces and using a dry cloth to remove excess. When using lubricant or corrosion protection compounds, be careful to avoid the adjacent surfaces and always follow the manufacturer's instructions.

## Track

Keep track free from obstruction and excessive dirt or water. Visible surfaces should be cleaned using a damp cloth and mild detergent, then wiped dry.

Where fitting to the outside of the building, it is recommended that the appropriate track is specified.

## Hangers & Pivots

All hangers are fitted with lubricated ball-bearings or plain bearings, requiring no greasing. If doors 'settle' and door clearance is reduced causing friction, raise the door by the hanger adjustment nuts.

Wash as per the above recommendation and apply a light application of corrosion preventative to all surfaces, using a dry cloth to remove excess.

## Guides

Guide roller and guide channel must be kept clear and free of obstructions.

Wash as per the above recommendation and apply a light application of corrosion preventative to all surfaces, using a dry cloth to remove excess.

## Rollers

All bottom rails should be free from obstruction and excessive dirt or water. Visible surfaces should be cleaned using a damp cloth and mild detergent, then wiped dry. All rollers are fitted with sealed precision bearings requiring no maintenance.

## Hinges

Visible surfaces should be cleaned using a damp cloth and mild detergent, then wiped dry. Apply a light application of corrosion preventative to all surfaces, using a dry cloth to remove excess. Repeat at intervals no greater than 3 months.

## Flush Bolts

Visible surfaces should be cleaned using a damp cloth and mild detergent, then wiped dry. Apply a light application of lubricant to internal mechanisms and bolt using a suitable nozzle-spray.