



SHOP PRESS

PNEUMATIC & HYDRAULIC

SP-50EAM



Scale & Sliding Cylinder with Handle and Rotatable Knob

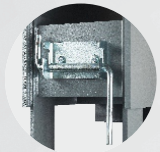

Winch Handle Holder



Winch Protection Cover

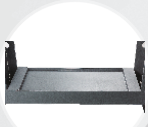

Spare Parts Tray



Well-Designed Legs with Bolt Holes



Quick Detachable Top Cover



Pulley Protection Cover



Working Bench Pin with Plastic Sleeve at One End



Handle Assy Holder



Pneumatic Foot Pedal Switch

Model	Capacity	Net Weight	Packing Size	Working Air Pressure	A	B	C	D	E	G	G2	R	M
SP-50EAM	50t	244kgs	182x110x40.5cm	0.9-1.2MPa	1080	750	1850	200	650	120	820	200	280

SP-50EAM

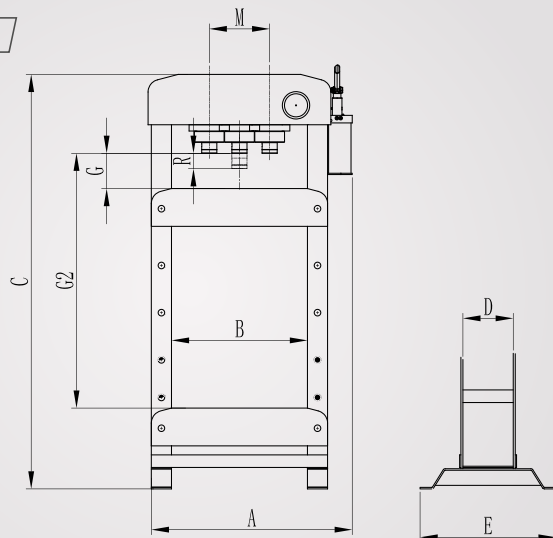

Features

- Safety valve
- Industry seals
- Double speed pump
- Automatic spring return of piston
- Legs with bolt holes for fixing to the floor
- Same cylinder assy as Snit pneumatic jacks
- Ergonomics operation handle and winch handle holder
- Winch protection cover and pulley protection cover for hand safety