



SHOP PRESS

HYDRAULIC

SP-20EM



Scale & Sliding Cylinder with Handle and Rotatable Knob



Quick Detachable Top Cover



V-block & Up-down Moveable Pins



Working Bench Pin with Plastic Sleeve at One End



Well-Designed Legs with Bolt Holes



Handle Assy Holder

Model	Capacity	Net Weight	Packing Size	Working Air Pressure	A	B	C	C1	D	E	G	G2	R	M
SP-30EAM	30t	131kgs	160x77x33cm	0.9-1.2Mpa	840	540	1650	1850	148	540	75	990	180	240

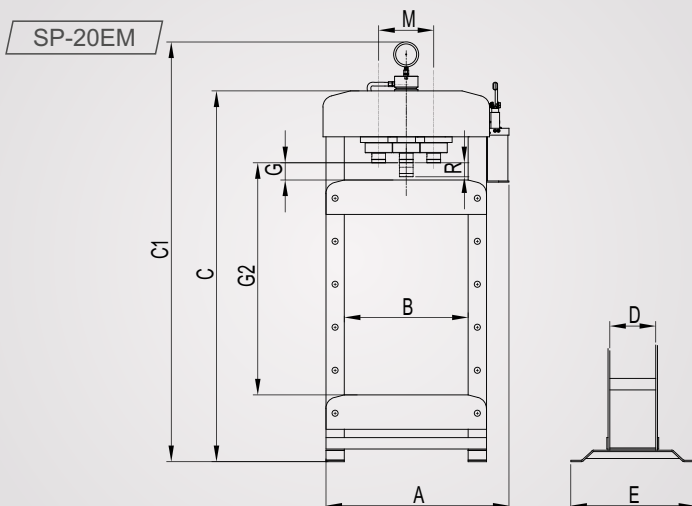

Features

- Safety valve
- Industry seals
- Double speed pump
- Legs with bolt holes for fixing to the floor
- Same cylinder assy as Snit pneumatic jacks
- Ergonomics operation handle and winch handle holder