



SHOP PRESS

PNEUMATIC & HYDRAULIC

SP-100EAM



Scale & Sliding Cylinder with Handle and Rotatable Knob



Quick Detachable Top Cover

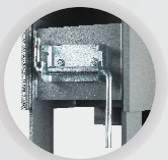

Winch Handle Holder



Pulley Protection Cover



Winch Protection Cover



Working Bench Pin with Plastic Sleeve at One End

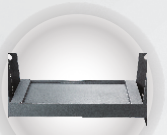

Spare Parts Tray



Handle Assy Holder



Well-Designed Legs with Bolt Holes

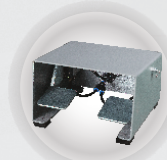

Pneumatic Foot Pedal Switch

Model	Capacity	Net Weight	Packing Size	Working Air Pressure	A	B	C	D	E	G	G2	R	M
SP-100EAM	100t	650kgs	195x130x40cm	0.9-1.2MPa	1255	850	1938	280	750	185	885	300	360

SP-100EAM

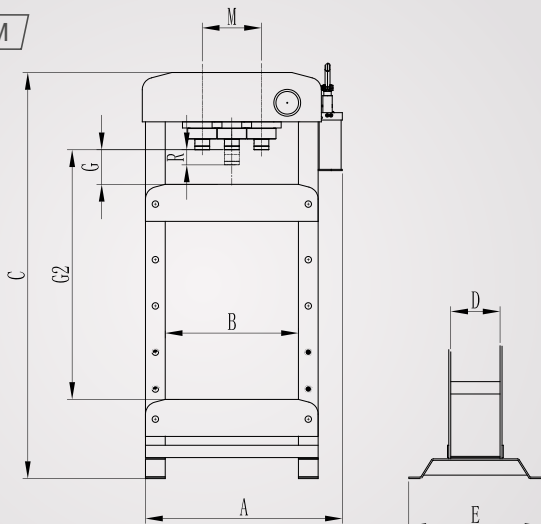

Features

- Safety valve
- Industry seals
- Double speed pump
- Automatic spring return of piston
- Legs with bolt holes for fixing to the floor
- Same cylinder assy as Snit pneumatic jacks
- Ergonomics operation handle and winch handle holder
- Winch protection cover and pulley protection cover for hand safety
- Foot-operated double-acting pneumatically controlled high speed makes the piston rod reset quickly when releasing the pressure of relief valve.