

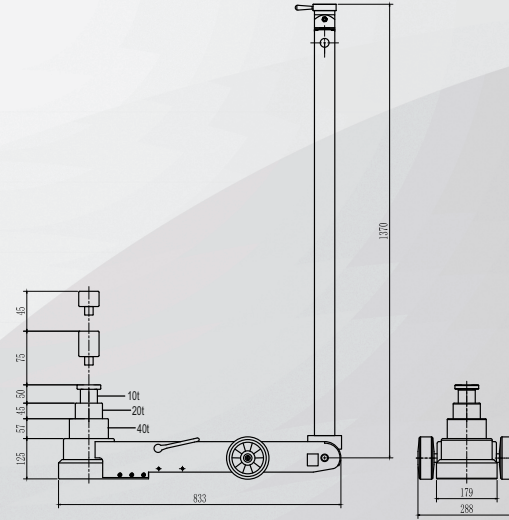

# PNEUMATIC HYDRAULIC JACK

## S50-3JL

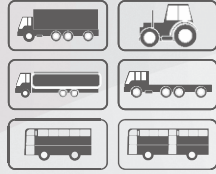

## S60-3JL

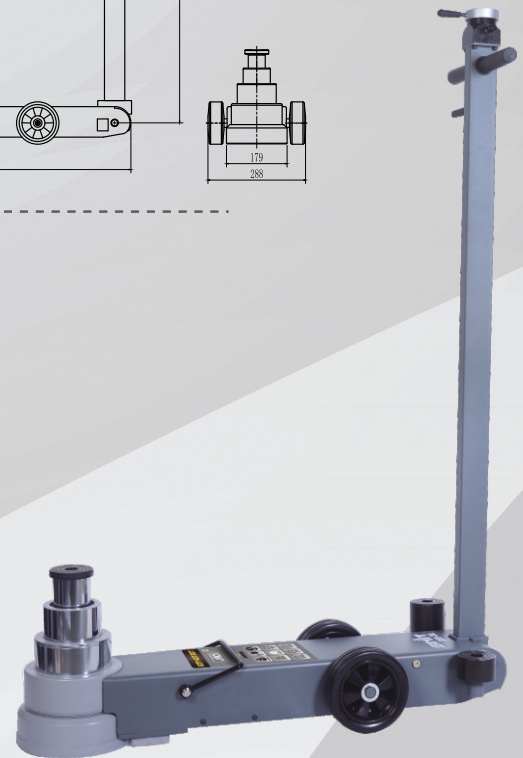
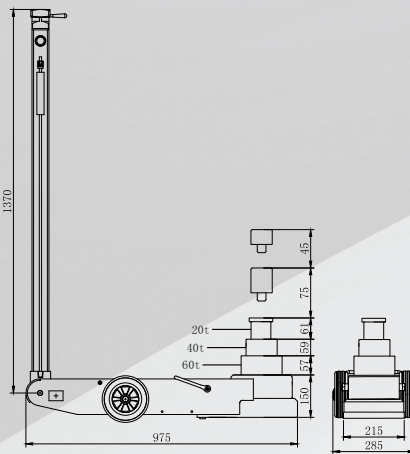
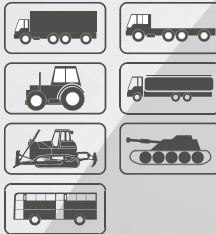

| Model  | Capacity    | Net Weight | Packing Size | Working Air Pressure | Min Height | Max Height | Lifting Height                   | Extension Height |
|--------|-------------|------------|--------------|----------------------|------------|------------|----------------------------------|------------------|
| S50-3J | 50t/25t/10t | 61kgs      | 92x31x27cm   | 0.9 ~1.2Mpa          | 160mm      | 472mm      | 50t:62mm<br>25t:61mm<br>10t:69mm | 75mm+45mm        |
| S60-3J | 60t/40t/20t | 70kgs      | 92x31x27cm   | 0.9 ~1.2Mpa          | 177mm      | 544mm      | 60t:82mm<br>40t:81mm<br>20t:84mm | 75mm+45mm        |

## Features

- Slow down valve
- Imported sealing from USA
- Hard chrome plated both internal & external cylinder
- XTP industry sealing(double sealing function)
- Safety overload valve
- Self-return switch for safe working
- Oil anti-back system