

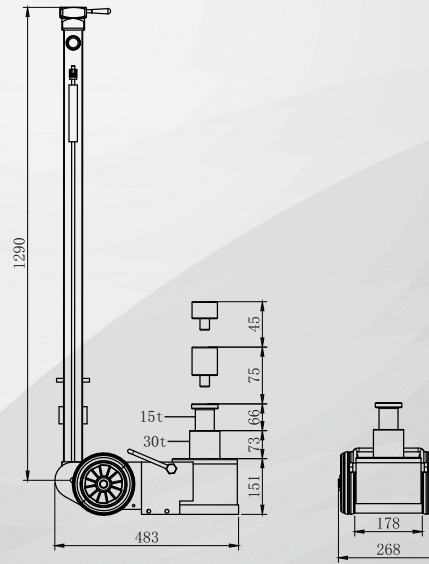

PNEUMATIC HYDRAULIC JACK

S30-2EL



S40-2EL

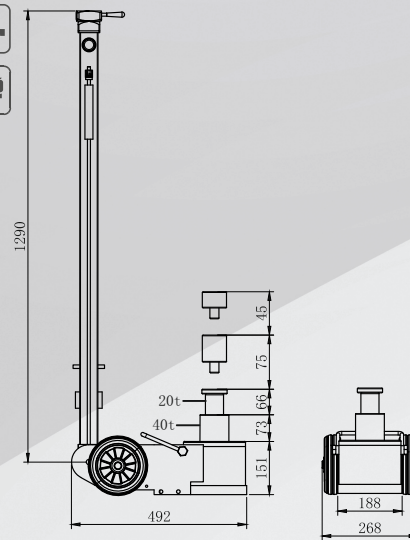
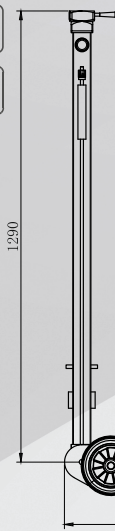

Model	Capacity	Net Weight	Packing Size	Working Air Pressure	Min Height	Max Height	Lifting Height	Extension Height
S30-2EL	30t/15t	33.9kgs	50x28x21cm	0.9 ~1.2Mpa	151mm	410mm	30t:73mm 15t:66mm	75mm+45mm
S40-2EL	40t/20t	36kgs	50x28x21cm	0.9 ~1.2Mpa	151mm	410mm	30t:73mm 15t:66mm	75mm+45mm

Features

- Slow down valve
- Imported sealing from USA
- Hard chrome plated both internal & external cylinder
- XTP industry sealing(double sealing function)
- Safety overload valve
- Self-return switch for safe working
- Oil anti-back system