

2-POST LIFTS
Electrohydraulic

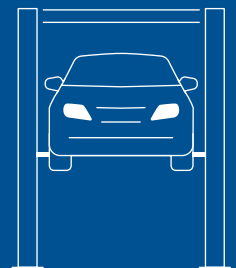

 **Ravaglioli**

RAV
KPH350.40
KPH350.45

**Electrohydraulic
2-post lift without base,
with asymmetric arms
and symmetric posts
that enable an easy
access to the pick-up
points of the vehicle.**



- Shut-off bar to prevent damage caused by lifting high vehicles.
- Two pistons for intensive use designed to minimise down-time, by requiring little maintenance.
- Mechanical safety latch with automatic engagement ensuring maximum safety when lift is in standing position.
- Manual release by lever.



Arm safety locking with automatic engagement and automatic release when the arm reaches the floor.

Capacity



4

KPH350.40
Recommended
for lifting cars and
pickups.



4.5

KPH350.45
Recommended for
lifting vans.

Scope of delivery:



65 mm
spacers.

2

support brackets
for spacers.



Powder coating for
a longer lifetime.

Technical Data

Model KPH350.40

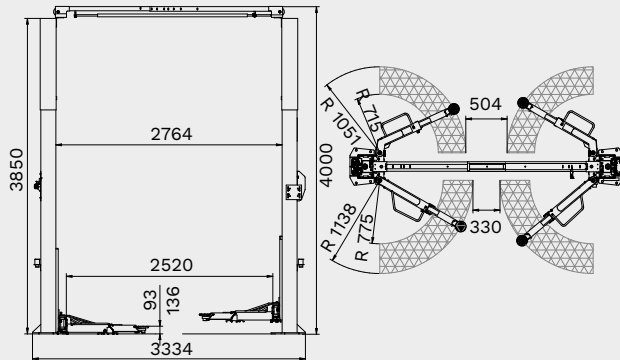

Model KPH350.45

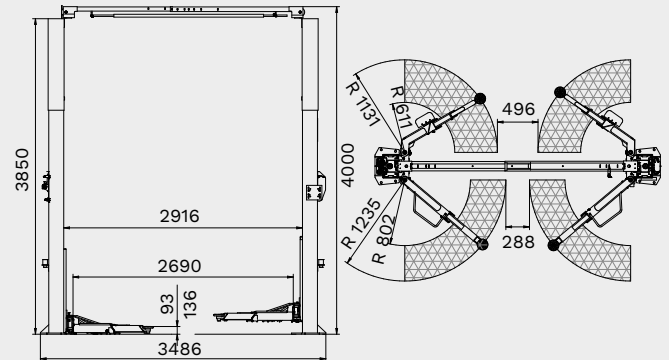

KPH350.40	
Item no.	Voltage
KPH-40ECGA	400/50/3ph
KPH-40NCGA	230/50/1ph

KPH350.45	
Item no.	Voltage
KPH-45ECGA	400/50/3ph

	KPH350.40	KPH350.45
Capacity	4,000 kg	4,500 kg
Max. lifting height	1,863 mm (1,928 mm with extensions)	1,863 mm (1,928 mm with extensions)
Lifting time	54 s	54 s
Min. pad height	100 mm	100 mm
Max. pad height	136 mm	136 mm
Column distance (internal)	2,764 mm	2,916 mm
Drive-through width	2,506 mm	2,659 mm
Max. usable height	3,850 mm	3,850 mm
Surface coating	powder coated	powder coated
Arm layout	asymmetrical	asymmetrical
Telescopic front arms	2 stages	3 stages (S)
Telescopic rear arms	2 stages	2 stages (L)
Min. front arm length	715 mm	611 mm
Max. front arm length	1,051 mm	1,131 mm
Min. rear arm length	775 mm	802 mm
Max. rear arm length	1,138 mm	1,235 mm
Width	3,334 mm	3,486 mm
Height	4,000 mm	4,000 mm
Weight	725 kg	750 kg
Driving power	2.2 kW	2.2 kW

* S = short; L = long



RAV Italy

Ravaglioli S.p.A.

Via Primo Maggio 3
Pontecchio Marconi
40037 Sasso Marconi BO

+39.051.6781511
+39.051.846349
rav@ravaglioli.com

RAV France

RAV France SARL

4, Rue Longue Raie
ZAC de la Tremblaie
91220 Le Plessis Pâté

+331.60.86.88.16
+331.60.86.82.04
rav@ravfrance.fr

RAV Germany

BlitzRotary GmbH

Hüfänger Straße 55
78199 Bräunlingen
Germany

+49.771.9233.0
+49.771.9233.99
ravd@ravaglioli.com

RAV UK

Vehicle Service Group UK Ltd

3 Fourth Avenue,
Bluebridge Industrial Estate
Halstead, Essex, CO9 2SY, UK

+44.1787.477711
+44.1787.477720
rav@ravaglioli.com

DRD40U (01)

Technical data and composition presented in this catalogue may vary.
Pictures reproduced are only indicative.

Member of VSG - Vehicle Service Group
a DOVER company

