

# **AREX** zero 1

## OPERATOR'S MANUAL

9mm



**AREX**



## SAFETY RULES

Please read this operator's manual carefully before handling your firearm. The following general firearms safety rules have been included in this manual by Arex d.o.o. as an important reminder that firearm safety is your responsibility. If mishandled, firearms can be dangerous and can be used to cause serious injury, damage to property and death.



**WARNING:** All firearms are loaded at all times. Even when a firearm is not loaded, treat it as if it was!

1. Never point a firearm at anyone or anything you are not willing to destroy. Be aware of the muzzle direction at all times. A **SAFE DIRECTION** means that the firearm is so pointed that it would not cause injury or unwanted damage, even if it would discharge.
2. Keep your **FINGER OFF THE TRIGGER** and outside of the trigger guard unless actually applying pressure to it (always keep your finger outside of the trigger guard while handling the firearm without intention to shoot, while loading or unloading the firearm, while pulling the firearm out of the holster or returning it to the holster).
3. When picking up or receiving a firearm always **CHECK WHETHER IT IS LOADED** or not (see Clearing, Pg. 14). Never give a firearm to or take it from anyone unless the action is open and the magazine and chamber are free of ammunition.
4. Be positive of the **TARGET AND BACKSTOP** beyond. Know that a fired bullet can penetrate the intended target as well as obstacles such as ceilings, floors, walls, doors and windows and it can ricochet off almost anything it strikes.
5. Be sure that you are using **CORRECT AMMUNITION** for the specific firearm, verify that it is factory loaded and that it is not damaged in any way (see Ammunition, Pg. 16).
6. Before firing, make sure the chamber is clear of any ammunition or empty cases and **CHECK THE BARREL** of the unloaded firearm (see Malfunction procedures, Pg. 23) for any possible obstructions.
7. Before firing any firearm, make sure that you **UNDERSTAND HOW TO OPERATE** it correctly. Lack of familiarity with the firearm can result in serious accidents. Attend a certified training course with any firearm you intend to use or with which you are not sufficiently familiar.
8. Always **WEAR HEARING AND EYE PROTECTION** when using a firearm. Hearing damage is accumulative and irreversible, severe hearing loss can result from even a single heard gunshot. A spent casing ejected at high speed from self-loading firearm, burning propellant particles and parts of bullet ricocheting backwards can cause serious injury or permanent blindness.
9. Keep all body parts, especially the hands and fingers, away from the muzzle to avoid injury or burns. Be sure that no part of either hand touches or interferes with the slide during firing. The slide moves backward with considerable speed and may cause serious injury.
10. Avoid the use of any alcoholic beverages or drugs before or during your use of a firearm.
11. Firearms should be locked and stored separately from ammunition and out of the reach of children and/or any untrained/unauthorized individuals.



**WARNING:** Discharging firearms in poorly ventilated areas, cleaning firearms, or handling ammunition may result in exposure to lead, a substance known to be associated with birth defects, reproductive harm and other serious injury. Have adequate ventilation at all times. Wash hands thoroughly after exposure.



**STOP! Know how to clear this pistol before attempting to operate.**

**Clearing the Pistol** -The AREX *zero 1* pistol is not considered “clear” unless:

1. The magazine is removed from the pistol
2. The slide is opened and/or locked to the rear and
3. The chamber is free of ammunition or empty cases.

**To clear the AREX *zero 1* Pistol** (see Clearing, Pg. 14, for detailed explanation):

1. Make sure fingers are outside of the trigger guard and the pistol is pointed in a safe direction at all times!
2. Engage manual safety. Push the safety lever up (left or right) to its uppermost position.
3. Remove magazine. Depress the magazine release button (left or right) and remove the magazine from the pistol.
4. Open and lock slide. While pointing the pistol in a safe direction, lock the slide open by pulling the slide rearward, releasing it, pulling it back again and pressing the slide catch-release/decocker upward at the same time. Watch for a single cartridge or empty case (i.e. “brass”) to be ejected from the pistol.
5. Inspect chamber. Inspect chamber for the presence of a cartridge or empty case either:
  - Visually - by looking into chamber through the open ejection port or
  - Physically - by inserting a finger into chamber through the open ejection port to check for the presence of a cartridge or empty case.
6. Remove any cartridges. Clear cartridges or empty cases from the chamber or from within the pistol.

The AREX *zero 1* pistol is now considered “Clear.”



**WARNING:** A discharging firearm has the capability of taking your life or the life of someone else! Be extremely careful with any firearm. An accident can occur at any time and is usually the result of ignoring basic safety rules.



**WARNING:** Read and understand all warnings in this operator’s manual. Failure to follow any of the warnings listed herein could result in material damage, serious injury or death.

# **AREX zero 1**

## OPERATOR’S MANUAL



AREX d.o.o. Šentjernej  
Trubarjeva cesta 7, SI-8310 Šentjernej, Slovenia, EU  
NCAGE: 1064Q  
Phone: +386 7 393 34 50 / Fax: +386 7 393 34 51  
info@arex.si  
[www.arex.si](http://www.arex.si)

## TABLE OF CONTENTS

Safety Rules & Basic Clearing	Inside Cover
<b>Section 1</b> Introduction	<b>5</b>
<b>Section 2</b> Nomenclature	<b>7</b>
<b>Section 3</b> Specifications	<b>10</b>
<b>Section 4</b> Function & Operation	<b>11</b>
Cycle of Operation	11
Safety Features	12
<b>Section 5</b> Instructions for Use	<b>14</b>
Clearing Procedure	14
Ammunition	16
Filling & Emptying the Magazine	17
Loading	18
Sights and Aiming	20
Firing	21
Unloading	22
Malfunction procedures	23
Storage & Transport	24
Selection & Use of a Holster	24
<b>Section 6</b> Disassembly & Assembly	<b>25</b>
Disassembly	25
Magazine Disassembly	27
Assembly	28
Magazine Assembly	29
Function Check	30
<b>Section 7</b> Cleaning & Maintenance	<b>31</b>
Cleaning	31
Inspection	32
Lubrication	33
Troubleshooting Problems & Repair	34
Warranty Registration Information	34
<b>Section 8</b> AREX <i>zero 1 Tactical</i> (model specific information)	<b>35</b>
<b>Section 9</b> Accessories	<b>38</b>
<b>Section 10</b> Parts List	<b>39</b>
Exploded View	40
Firearms Service Record	41

## INTRODUCTION

The AREX *zero 1* was developed by Arex to meet the need for a safe, durable and precise self-loading handgun with an external hammer operating in single- and double-action mode. Incorporating a well-proven modified Browning link-less short recoil system of operation, the AREX *zero 1* hammer fired design ensures a consistent performance from the first shot to the last.

The AREX *zero 1* handgun incorporates several redundant safety features, which include a firing pin block acting as a passive drop safety. This safety is positively blocking the firing pin unless the trigger is held to the rear and will prevent the firing pin from contacting the primer in the event that the handgun is dropped or struck. The frame incorporates an ambidextrous manual safety lever that provides positive disengagement between trigger bar and the hammer thus helping prevent accidental discharges even if trigger is inadvertently depressed. The disconnecter prevents AREX *zero 1* from firing when the slide is not in battery.



**WARNING:** AREX *zero1* pistol will fire with the magazine removed, when a cartridge is in the chamber, the trigger is pressed and the manual safety is not engaged.

The take down lever acts as a disassembly safety and precludes the AREX *zero 1* from being disassembled unless the slide is held fully to the rear, normally clearing the chamber of a cartridge/case in the process. No tools are needed and there is no need to operate the trigger in order to disassemble the pistol for maintenance.

The design of the AREX *zero 1* allows the operator to visually and/or tactilely assess the status of the firearm by means of a loaded chamber indicator located on the top of the slide. Numbered witness holes on the back of the magazine housing allow the operator to verify the amount of ammunition present in the magazine without emptying it.

All vital operational controls on the AREX *zero 1* handgun are ambidextrous. Safety levers are ergonomically positioned above the grip panels for manipulation using right or left thumb. An easy-to-access enlarged ambidextrous magazine release button is located at the rear of the trigger guard. The slide catch-release doubles as a decocking lever and is located on the left side of the frame in front of the safety.

The AREX *zero 1* design incorporates a unique dual-purpose slide catch-release/decocking lever intended primarily for administrative loading and manipulation of the slide. This solution minimizes the number of external controls without compromising safety and function. Pushing down on the left-side frame-mounted lever will first release the slide (if locked to the back) and then optionally safely lower the hammer (from its cocked position).

The AREX *zero 1*'s light but tough aluminum frame features replaceable, thin, ergonomically contoured polymer grip panels as well as Picatinny rail (MIL-STD-1913) equipped extended dustcover. Vertical grooves in front and back of the pistol's grip also enhance traction during handling and firing.

Milled from a solid block of high carbon steel and surface enhanced with a corrosion resistant nitro-carburized finish, the slide on the AREX *zero 1* features drift adjustable metal sights with contrast white dots enabling quick target acquisition (front blade can be exchanged for elevation adjustment and both sights are drift adjustable for windage). Rear as well as front slide serrations ensure firm grip during slide manipulation.

Arex, well known for its defense products and technical expertise, has outfitted the AREX *zero 1* with a one-piece cold hammer forged barrel. The barrel — made from chromolly steel — ensures excellent precision and long service life. Barrel on test AREX *zero 1* pistol has fired more than 30,000 rounds in endurance tests in 2014.

AREX *zero 1* pistols use high quality steel magazines with 17-round capacity as standard (18-round as option for Standard and Combat pistol and 15-round for Compact version). Reduced capacity magazines are available where legal restrictions apply.

Quality of the AREX *zero 1* pistols is maintained by constant internal quality control according to ISO 9001: 2008 standard. AREX *zero 1* comply with strict military standards for reliability with high Mean Rounds Between Stoppages count achieved during testing. AREX *zero 1* passed extreme temperature and hostile environment tests as well as all required drop tests according to NATO D14 test criteria. A service life of 30.000 rounds is expected.

The firing mechanism with exposed spurred hammer operates in classical single- and double-action modes where, pressing the trigger cocks the hammer and immediately releases it firing the first chambered cartridge. All subsequent cartridges are fired in the single-action mode as slide automatically recocks the hammer after the first and each subsequent shot is fired (hammer remains cocked after each cycling of the slide).

Smooth and relatively short double-action trigger pull provides good accuracy on first shot and single-action trigger renders a short, light take-up with a solid break on all subsequent shots. Short and positive reset on trigger release allows for fast and accurate follow-up shots. Large trigger guard was conceived for use with various gloves. AREX *zero 1* pistol incorporates an internal extractor which allows for a closed slide construction and delivers same or better reliability with fewer parts as compared to external extractor designs.

The AREX *zero 1*'s extended aluminum frame adds to the rigidity of construction and provides full-length slide guides for smooth, stress-free operation prolonging frame service life. Standardized mounting interface machined into extended dustcover of the frame can accept a wide variety of lights, laser aimers and other accessories. The strength of similar interfaces found on polymer framed handguns cannot be compared to AREX *zero 1*'s Picatinny (MIL-STD-1913) rail which has been tested with mounted accessories weighing up to 11 ounces (300 grams). The rails are sturdy enough to serve as a mounting interface for fixing the handgun itself during firing.

**NOTE:** Improperly designed or installed accessories may result in damage to the mounting grooves and/or the pistol. Such damage is not covered under the limited lifetime warranty. Be certain to use only appropriate accessories and follow installation procedures and precautions carefully.

AREX *zero 1* pistols are proudly made in Arex's factory in Slovenia, EU. The AREX *zero 1* is well suited for law enforcement, military and security use, as well as for civilian self-defense, recreational and sport shooting. Covered by Arex's limited lifetime warranty, the AREX *zero 1* is a solid design, engineered towards long-term durability. Materials and applied technologically advanced manufacturing processes will ensure extremely long and low-maintenance life cycle.

## NOMENCLATURE

Figure 1 — AREX zero 1 (cutaway view)

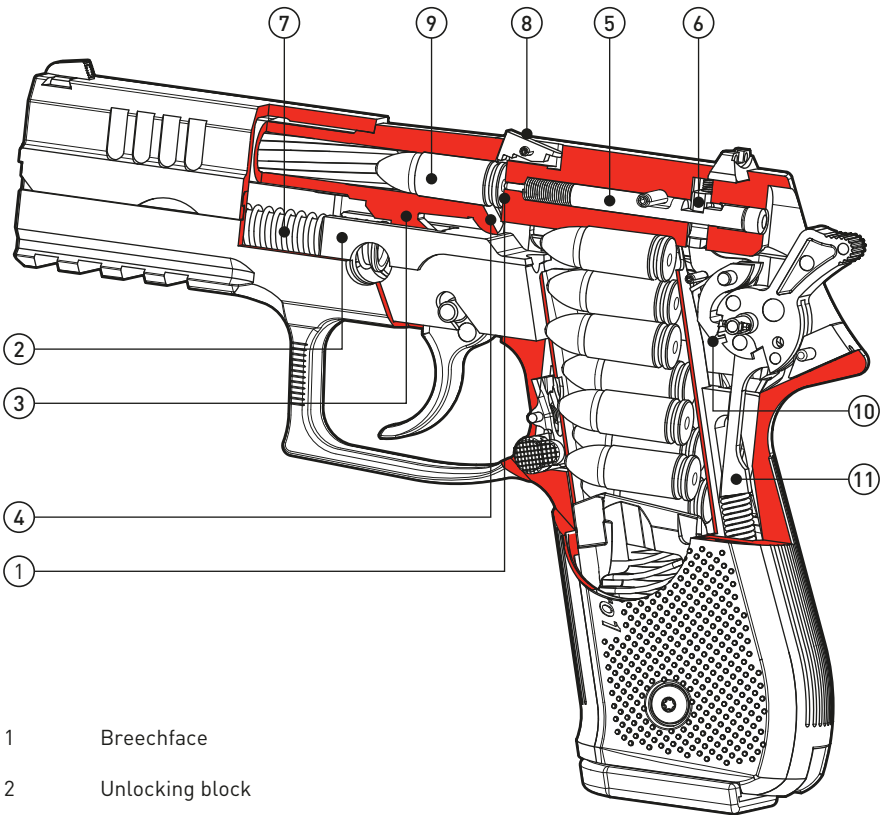

- 1 Breechface
- 2 Unlocking block
- 3 Barrel's guiding lug
- 4 Feed ramp
- 5 Firing pin
- 6 Firing pin safety
- 7 Recoil spring assembly
- 8 Loaded chamber indicator
- 9 Cartridge in the chamber
- 10 Sear
- 11 Hammer strut with spring

Figure 2 — AREX zero 1 (left side view)



- 1 Front sight
- 2 Slide
- 3 Disassembly lever
- 4 Slide catch-release/decocker
- 5 Rear slide serrations
- 6 Manual safety lever, left
- 7 Hammer
- 8 Picatinny-rail
- 9 Magazine release button, left
- 10 Grooved back strap
- 11 Grip panel, left



Figure 3 — AREX zero 1 (right side view)



- 1 Rear sight
- 2 Manual safety lever, right
- 3 Loaded chamber indicator
- 4 Ejection port
- 5 Frame
- 6 Front slide serrations
- 7 Grip panel, right
- 8 Magazine floorplate
- 9 Trigger
- 10 Trigger guard
- 11 Magazine release button, right
- 12 Grooved front strap

## SECTION 3

### SPECIFICATIONS

Caliber: 9mm Luger (9x19mm), 9mm IMI (9x21mm)  
 Operating Principle: Short recoil  
 Action Type: modified Browning linkless locking system  
 Trigger System: Single- and Double-action, Hammer fired

### DIMENSIONS & WEIGHT

	STANDARD	COMBAT	COMPACT
Length	7.7 in / 195 mm	7.3 in / 185 mm	
Barrel Length	4.3 in / 108 mm	3.9 in / 98 mm	
Sight Radius	5.9 in / 151 mm	5.6 in / 141 mm	
Height	5.7 in / 144 mm		5.3 in / 134 mm
Width (slide)	0.98 in / 25 mm		
Width (frame)	1.1 in / 27 mm		
Width (safety levers)	1.46 in / 37 mm		
Weight (without magazine)	29 oz / 826 g	28 oz / 795 g	27.5 oz / 780 g
Weight (empty magazine)	3 oz / 85 g		2.8 oz / 80 g
magazine capacity	17 / 18		15

### OTHER DATA

Trigger Pull SA	5.5 lb / 2.5 kg
Trigger Pull DA	13 lb / 6.0 kg
Trigger Travel DA	0.5 in / 13 mm
Reset Travel SA	0.16 in / 4 mm
Barrel Profile/Twist	6 grooves, right-hand twist
Barrel Twist Rate	9.8 in / 250 mm

### MISCELLANEOUS

Warranty: Limited Lifetime Warranty for the original retail (commercial/civilian) purchaser, one year for law enforcement and military customers

Picatinny Rail: Extended MIL-STD-1913 rail with four segments located under dust cover — rated to 11 ounces (300 grams) load for accessory light, lasers and aimers with no impact on performance

Service Life: Up to 30,000 rounds

Safety: Firing pin block, manual safety, hammer safety stand-off.  
 Pistol passed drop tests according to NATO D14 test criteria

Disassembly: No tools required for user disassembly, slide must be fully retracted and no trigger pull is necessary for disassembly.  
 Minimal tools required for detailed, depot level disassembly

**FUNCTION AND OPERATION****CYCLE OF OPERATION**

The cycle of operation is a repeating sequence of mechanical events taking place during operation of a self-loading firearm. The sequence for the AREX *zero 1* pistol begins with a loaded magazine inserted into the magazine well and the slide being released from its rearmost position.

**1. Feeding: Removal of a round from the magazine**

Racking the slide (pulling it briskly back to its rearmost position and releasing) or depressing the slide catch-release/decocking lever (if slide is locked to the rear) allows the recoil spring to expand, driving the slide forward. The bottom part of the slide's breechface (part of slide that closes the barrel), passes between the feed lips, stripping the top round from the magazine and pushing it towards the chamber. The bullet slides up the barrel's feed ramp, allowing the base of the cartridge to pivot upwards on the breechface.

**2. Chambering: Placing and seating the round into the chamber of the barrel**

The recoil spring continues to expand, driving the slide forward with breechface pushing the cartridge into the chamber. As the base of the cartridge pivots upwards, the slide mounted internal extractor engages the cartridge's rim. As the cartridge is completely chambered the slide's breechface comes in contact with the enlarged rear portion of the barrel and starts pushing it forward.

**3. Locking: Closing and locking of the action prior to the shot**

When slide pushes the barrel forward it forces the angled surfaces on its guiding lug against opposing angled surfaces on the unlocking block located in the frame. This action pivots the rear portion of the barrel upwards until its stepped forward edge engages the forward edge of the ejection port. As the enlarged rear portion of the barrel locks into slide's ejection port (the breech is locked), the frame-mounted disconnector is allowed to pivot upwards into a relief cut milled on the bottom of the slide, thus allowing the trigger bar access to hammer and sear. The locking phase is completed when the slide reaches its forward limit of travel (i.e. slide is "in battery").

**4. Firing: Ignition of the cartridge's primer and propellant**

As the operator presses the trigger (moving it back), the hammer is either cocked and released (in double-action mode) or released from its cocked position (in single-action mode). As the trigger reaches its rearmost position, the firing pin block plunger is pushed up by the trigger mechanism so it unblocks the firing pin just before the falling hammer hits it. When the hammer, driven by the expansion of the hammer spring, hits the firing pin, it is propelled forward, protruding through the hole in the slide's breechface, striking the primer. The primer detonates, which, in turn, ignites the propellant gunpowder in the cartridge. The bullet is pushed out of the cartridge case and forced down the barrel by the expanding gases. Rifling inside the bore "grips" the bullet, making it spin, thus gyroscopically stabilizing its flight.

**5. Unlocking: Removal of any blocking mechanism to allow the opening of the breech**

The force of the expanding gases causes the bullet to move forward in the barrel but also pushes the cartridge case rearward against the slide's breechface, initially pushing both the slide and barrel back in unison since the barrel's enlarged rear portion is locked in the ejection port. The slide's ejection port pushes back on the stepped forward edge of the enlarged rear portion of the barrel and after approximately 4 millimeters of travel, the barrel is pulled downward due to the engagement of the angled surfaces on the barrel's guiding lug with those located on the frame mounted unlocking block. The unlocking block disengages the barrel from the slide (after another 4,5 millimeters of conjoined travel) and stops it while the slide continues moving rearward independent from the barrel.

#### 6. Extracting: Removal of the fired cartridge case or live round from the chamber

With the barrel now arrested by the frame mounted unlocking block, the slide continues to move towards the rear. The internal slide mounted extractor, hooked to the cartridge case's rim, pulls the fired cartridge case (or live round - if the slide is retracted manually) from the chamber.

#### 7. Ejecting: Expulsion of the fired cartridge case or live round from the firearm

The extractor mounted inside the slide on its right side, continues to pull the cartridge case (or live round - if the slide is retracted manually) rearwards. As the slide moves rearward, the base of the cartridge case is struck against the ejector, positioned in the left side of the frame, behind the magazine well. Extractor creates a moving pivot point on the right and the frame mounted ejector creates a stopping contact point on the left, rotating the cartridge case (or live round) to the right, ejecting it outwards through the ejection port on the right side of the slide.

#### 8. Cocking: Resetting the hammer to allow subsequent shots to be fired in single-action mode

In the first few millimeters of rearward travel, the slide passes over the disconnecter and presses it downward, disengaging the trigger bar from the hammer and sear. As the slide continues to move back towards its rearmost position it cocks the hammer compressing the hammer spring. The sear engages the hammer, holding it in cocked position, regardless of the position of the trigger (if the shot has just been fired, the operator still holds the trigger to the rear).

#### 9. Repeating or ending of the cycle of operation

Once fully to the rear, the compressed recoil spring pushes the slide forward, closing the action and taking the next cartridge from the magazine (if a cartridge is present) into the chamber while hammer remains cocked. If the magazine is empty (e.g. the last round was fired), the magazine follower lifts the slide release into position where it blocks the forward progress of the slide and holds it open.

## SAFETY FEATURES

The AREX *zero 1* incorporates the following safety features:

### 1. Firing Pin Safety

The slide mounted firing pin safety helps prevent accidental discharge from impact if the AREX *zero 1* is struck or dropped. When at rest, the spring loaded firing pin block arrests the firing pin and blocks the firing pin from moving forward in the firing pin tunnel. Once the trigger is pressed to its rearmost position, the trigger mechanism pushes up on the firing pin block plunger which releases the firing pin (providing the slide is in battery) allowing the firing pin to move freely when hit by the hammer. The firing pin safety blocks the firing pin automatically as soon as the trigger is released.

### 2. Ambidextrous Manual Safety

The frame mounted manual safety also helps prevent accidental discharge by means of positively disengaging the trigger bar from the hammer and sear, which prevents the pistol from firing even if trigger is depressed. If one of the AREX *zero 1*'s manual safety levers, positioned on both sides of the frame, is pushed in its upper position, the pistol is put "on safe". This can be done whether the hammer is cocked or not. If the hammer is cocked the pistol can be fired in single-action mode once the safety is disengaged (moved to its lower position). A red circular mark is visible on both sides of the slide above safety lever, signifying manual safety is disengaged and pistol can be fired when trigger is depressed. The trigger moves freely when the safety is engaged, reminding the operator the pistol is "on safe".



**WARNING:** Do not depend on the red color mark alone to indicate the status of the manual safety because it could be erased in time.

### 3. Disconnecter

The disconnecter ensures that the AREX *zero 1*'s slide must be in battery to enable the pistol to fire. When the action is open or only partially closed (i.e. slide is out of battery), the disconnecter, mounted inside the frame, is pushed downward by the slide, disengaging the trigger from the hammer and sear thus precluding firing even if trigger is depressed. In battery, a relief cut milled on the bottom of the slide allows the disconnecter to pivot upwards enabling the trigger bar to engage the hammer or sear.

### 4. Disassembly Safety

The disassembly safety ensures that the slide is retracted fully to the rear, prior to disassembly. The disassembly lever is designed so that the cutout on the slide will only allow it to be rotated when the slide is in its rearmost position. Having to operate the slide prior to manipulation of the disassembly lever ensures that any round present in the chamber is extracted and ejected. Disassembly is carried out without manipulation of the trigger.

### 5. Decocking Lever (with dual function of slide catch-release)

The decocking lever on the AREX *zero 1* pistol is designed to safely decock the firearm. It is vital to safety because the AREX *zero 1* is a double- and single-action pistol. It is unsafe practice to decock a pistol by holding the hammer and pulling the trigger while attempting to ease the hammer forward manually. To decock your pistol, push down on the decocking lever (keeping your finger OFF the trigger). The AREX *zero 1*'s decocking lever is unique since it combines two functions in one control. It is constructed to function as a slide catch-release and a decocker, intended primarily for administrative loading of the handgun and locking the slide open. Pushing down on the lever will first close the slide (if locked to the back) and then lower the hammer to its safety stand-off position (if cocked). In the process of decocking, the hammer never reaches the firing pin which is additionally arrested by the firing pin safety.



**WARNING:** Always use the decocking lever to decock your AREX *zero 1* pistol. This is the only way to safely lower the hammer from the cocked position and prevent an accidental discharge. Manually lowering the hammer is potentially dangerous since it can prevent full application of the pistol's safety features.

### 6. Hammer safety stand-off

The AREX *zero 1* pistol incorporates a hammer safety stand-off position. This feature is active until the trigger is depressed and holds the hammer away from the firing pin. When the pistol is fired, the hammer rebounds and is automatically held in a stand-off position as the trigger is released thus preventing it to contact the firing pin.

### 7. Loaded Chamber Indicator

The loaded chamber indicator is located on the top of the AREX *zero 1*'s slide, just behind the barrel. It allows the operator to determine if there is a cartridge (or a cartridge case) inside the chamber, without opening the action (i.e. performing press-check). Indicator protruding 1 millimeter above the slide surface, which can be seen and felt, indicates a loaded chamber.



**WARNING:** AREX *zero 1* pistol does not feature a magazine disconnect, and is able to fire even if the magazine is removed. Pistol will fire when a cartridge is in the chamber, the manual safety is not engaged and the trigger is pressed.



**WARNING:** Never rely totally on mechanical safety devices. Like any mechanical device, a safety mechanism can fail or it can be inadvertently disengaged. Always keep the firearm pointed in a safe direction and finger off the trigger when not intentionally depressing it!

## INSTRUCTIONS FOR USE

## CLEARING

NOTE: Carry out this procedure whenever the firearm is picked up/handled without the intent to be fired immediately.

**1. Point the muzzle of the AREX zero 1 in a safe direction.**

Ensure the muzzle of the AREX zero 1 is pointed in a safe direction (see Safety rules, Pg. 2) and that the fingers are kept off the trigger and outside of the trigger guard at all times during firearm manipulation.

NOTE: It is a matter of good practice to rest the trigger finger on the frame and not on the front of the trigger guard.

**2. Remove the magazine.**

Depress either side of the ambidextrous magazine release button and remove the magazine from the magazine well.

NOTE: Magazine will fall free from the magazine well when the magazine release button is depressed. The absence of the magazine should always be verified by inserting a finger in the magazine well at the bottom of the grip.

**3. Open the action.**

Grasping the rear slide serrations, swiftly rack the slide (pulling it briskly back to its rearmost position and releasing) while keeping the muzzle pointed in a safe direction. Watch for a cartridge or empty case to be ejected out through the ejection port. Retract the slide fully to the back the second time. If another cartridge is ejected, STOP immediately and remove the magazine from the pistol (go to step 2). You can hold the slide to the rear or lock it to the rear by pushing upwards on the slide catch-release/decoding lever at this point.

NOTE: You can use front slide serrations to manipulate the slide if the safety is engaged.



**WARNING:** When using front slide serrations take extra care to keep your hands and fingers away from the muzzle while grasping the slide.

**4. Inspect the chamber and magazine well.**

Inspect the chamber for the presence of a cartridge or an empty case by looking through the open ejection port into the chamber, visually verifying that the chamber is empty. Verify that the magazine is not present in the magazine well, if it is present, STOP immediately and remove the magazine from the pistol (go to step 2). If visual inspection is not possible a finger should be physically inserted through the ejection port and the chamber felt for the presence of a round or an empty case.



**WARNING:** If the slide is closed when the finger is inside the ejection port, injury may occur.

**5. Remove any ammunition.**

Remove any cartridges or empty cases that were not ejected, from the chamber and from within the magazine well of the AREX zero 1 pistol.

NOTE: When the above described procedure is executed, the AREX zero 1 pistol is considered "CLEAR".

Figure 4,5,6: Clearing the AREX zero 1 pistol



Figure 4 — Remove magazine



Figure 5 — fully retract slide TWICE



Figure 6 — inspect chamber and magazine well

## AMMUNITION



**WARNING:** Arex d.o.o. specifically disclaims any responsibilities for any damage or injury that should occur because of, or as a result of, the use of faulty, remanufactured, or reloaded (hand loaded) ammunition, or of cartridges other than those for which the pistol was originally chambered for.

**NOTE:** The AREX *zero 1* pistol was designed to fire quality, factory-loaded ammunition, loaded to European C.I.P. (Permanent International Commission for the Proof of Small Arms) or US SAAMI (Sporting Arms and Ammunition Manufacturers' Institute) specifications for use specifically in handguns.

The following guidelines should be considered when selecting the correct ammunition for your pistol:

1. Be sure the ammunition you have chosen is compatible with your pistol - proper caliber, cartridge, bullet weight, etc. Caliber markings on the AREX *zero 1* pistol appear on the rear portion of the barrel and are visible through the ejection port on the right side of the slide.



**WARNING:** Using the wrong ammunition could result in serious injury or death. Catastrophic damage to the firearm could occur.

2. Prior to loading the pistol, carefully inspect all cartridges for the following abnormalities:

- Cracked, split, dirty or corroded cases
- Improperly seated projectiles and/or primers
- Damaged projectiles
- Projectile has been forced back into the case.



**WARNING:** Do not attempt to load or fire any of such cartridges. Upon firing, these conditions may result in increased chamber pressure that is above safe limits.

3. Do not attempt to fire ammunition that:

- Is foreign and/or outdated military surplus
- Is assembled with corrosive primer and/or propellant
- Was exposed to oil, grease, water or direct sunlight. If possible, remove contaminants before use and cool down ammunition exposed to direct sunlight or heat. (Exposure to sources of heat could raise the chamber pressure of the cartridge above safe limits.)
- Is loaded specifically for use in submachine guns.



**CAUTION:** Arex firearms are designed to function safely and reliably with a wide range of quality manufactured brass-cased ammunition loaded to commercial (C.I.P., SAAMI) or military (NATO) standards. Use of cast-lead bullets is not recommended.



## FILLING THE MAGAZINE

**NOTE:** Do not attempt to load more than the declared maximum number of cartridges into the magazine. Do not alter the shape of the magazine housing, follower or spring. To do so may cause stoppages or the magazine may not seat properly in the pistol.

To fill the magazine:

1. Hold the magazine with the back side of the magazine resting against the palm and its bottom preferably resting on a hard surface (e.g. tabletop).
2. Using the support (i.e. non-firing) hand, hold a cartridge to be loaded between the index finger and thumb with the projectile facing the palm.
3. Press the base of this cartridge down against the forward edge of the magazine follower or the top cartridge already in the magazine with the thumb of the firing hand. Use the thumb and index finger of the support hand to prevent the cartridge from slipping to either side of the loaded one.
4. Push the cartridge back into the magazine under the magazine feed lips with the base first.
5. Repeat steps 1-4 until the magazine is filled to capacity. The numbered holes in the back of the magazine allow the operator to confirm the number of cartridges loaded in the magazine.

**NOTE:** Observe the proper orientation of the cartridges. The magazine may allow cartridges to be loaded with bullets turned backwards in which case the firearm will not function and the cartridge may jam inside the chamber if an improperly loaded magazine is inserted and slide racked.

## EMPTYING THE MAGAZINE

Holding the magazine with its back side resting against the palm, exert pressure with a thumb on the base of the top cartridge and push each cartridge forward out of the magazine one at a time, until the magazine is empty.



Figure 7  
Filling the magazine



Figure 8  
Numbered witness holes



Figure 9  
Emptying the magazine

## LOADING THE PISTOL



**WARNING:** Forcefully inserting a loaded magazine into the pistol may cause the opened slide to close, chambering a cartridge and making the pistol ready to fire. When loading the AREX zero 1, always be sure the pistol is pointed in a safe direction with your fingers off the trigger and outside of the trigger guard. Failure to do so could cause you to inadvertently fire the pistol, resulting in serious injury or death.

Administrative Loading - Used primarily to load the pistol when it is being prepared for carry or not intended to be fired immediately.

**NOTE:** Slide is forward or locked to the back, chamber empty, magazine well empty.

1. Safety first - Make sure the pistol is pointed in a safe direction and fingers are outside of the trigger guard at all times during loading procedure!

**NOTE:** The AREX zero 1 pistol was designed so that loading and unloading (i.e. clearing) may be performed with the manual safety engaged (i.e. pistol "on safe") at all times. This can be used as an extra precaution against accidental discharge due to inadvertent trigger manipulation. It is however not obligatory if operator ensures that the fingers are kept off the trigger and outside of the trigger guard at all times during firearm manipulation. Front serrations should be used to manipulate the slide whenever manual safety is engaged.



**WARNING:** When using front slide serrations take extra care to keep your hands and fingers away from the muzzle while grasping the slide.

2. Insert the magazine - Insert the magazine filled with desired number of cartridges firmly into the magazine well. Tug on the magazine floorplate to insure that it is fully seated and engaged.

**NOTE:** The magazine floorplate and the bottom of the grip panels were purposely designed to allow the magazine to be grasped. There is also a distinct clearance between the bottom of the grip and inserted magazine floorplate.

3. Chamber a cartridge - Chamber a cartridge by depressing the slide catch-release/decocker (when slide is locked to the rear) or by pulling the slide fully to the rear and releasing it.



**WARNING:** Make sure your fingers are safely away from the ejection port when the slide is released to avoid injury.

**NOTE:** Do not ride the slide forward! The pistol was designed to load a cartridge by the force of the expanding recoil spring. Slowly closing the action (i.e. easing the slide forward) might cause the pistol to jam or not load the cartridge properly.



**CAUTION:** The pistol is now loaded and can be fired. When the manual safety is disengaged and the trigger is pressed, the pistol will fire. If the pistol is not to be fired immediately, proceed to the next step of the administrative loading process!

4. Decock the hammer or engage the manual safety - Decock the hammer by pushing down the slide catch-release/decocker or put the pistol "ON SAFE" by moving the manual safety lever to its uppermost position (on the left or right side of the frame). The pistol is now loaded, safe to carry in a holster and ready for use.

**WARNING:** Always use the decocking lever to decock your AREX zero 1 pistol.

5. Check the chamber is loaded - Visually or tactilely verify that the loaded chamber indicator protrudes above the top surface of the slide, confirming the cartridge is loaded in the chamber. It is not necessary to partially open the slide to perform the "press check".

**NOTE:** AREX zero 1 pistol gives operator multiple options for safe carry with a loaded chamber.

Safe carry conditions for the AREX zero 1 pistol:

A. Decocked - When the hammer is decocked the pistol may be carried without engaging the manual safety. With this carry method, the first shot will be fired in a double-action mode (longer, harder trigger).

B. Cocked and locked - If the safety is engaged (i.e. pistol is put "on safe") and the hammer remains cocked, the AREX zero 1 can be carried in so called "cocked & locked" condition. With this carry method, the first shot will be fired after the manual safety is pushed down (i.e. disengaged) in a single-action mode (shorter, lighter trigger).

C. Decocked and "on safe" - The manual safety can also be engaged and hammer decocked in which case the first shot will be fired in a double-action mode, after the manual safety lever is pushed down (i.e. safety disengaged).

All three carry methods are safe with the AREX zero 1 pistol provided that operator understands and appreciates their differences.

**WARNING:** It is considered unsafe to carry the AREX zero 1 or any other pistol with the hammer cocked without engaging manual safety due to the short and light single-action trigger. The firing pin safety and the hammer stand-off safety are nevertheless active and the pistol will not fire when struck or dropped and the trigger must be pressed in order to fire it.



Figure 10  
Inserting the magazine



Figure 11  
Use front serrations to retract slide if safety is engaged



Figure 12  
Decocking the hammer

**WARNING:** When using front slide serrations take extra care to keep your hands and fingers away from the muzzle.

## SIGHTS AND AIMING

The AREX *zero 1* is equipped with a three dot sighting system. The sights are adjustable for both windage (by drifting) and elevation (by replacement of the front sight). Sights are installed and carefully aligned by Arex technicians at our factory. Only a competent gunsmith should adjust or replace the AREX *zero 1* sights. Figure 13 shows correct sight alignment, table below shows common aiming and impact points errors.

NOTE: Your AREX *zero 1* pistol was test fired at the Arex factory for accuracy by ensuring the point of aim equals point of impact at 15 meters (17 yards). Individual results concerning accuracy and/or shot placement are affected by such factors as shooting stance, firing grip, trigger technique, ammunition and target distance.

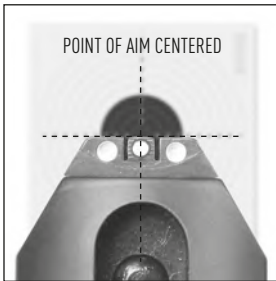

Figure 13  
Correct sight alignment

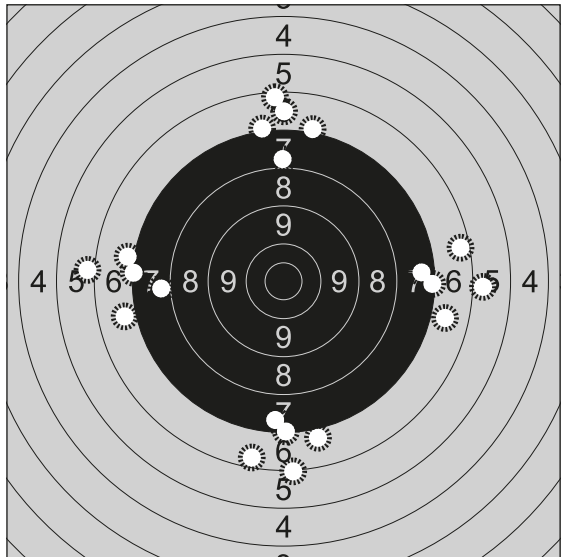

Figure 14 - Troubleshooting aiming/impact point errors

POSITION OF THE IMPACT POINT IN REGARD TO AIMING POINT (Figure 14)	POSSIBLE CAUSE	CORRECTIVE MEASURES
SHOTS HIGH ON TARGET	front sight not level with rear - too high	lower/align front sight in the rear sight notch
	front sight too low	replace front sight with a higher one
SHOTS LOW ON TARGET	front sight not level with rear - too low	elevate/align front sight in the rear sight notch
	front sight too high	replace front sight with a lower one
SHOTS LEFT ON TARGET	front sight left in the rear sight notch	center front sight in the rear sight notch
	sights not positioned correctly	shift front sight to the left if necessary also shift rear sight to the right
SHOTS RIGHT ON TARGET	front sight right in the rear sight notch	center front sight in the rear sight notch
	sights not positioned correctly	shift front sight to the right if necessary also shift rear sight to the left

## FIRING



### WARNING:

1. Be sure of your target and what is behind it! Without proper backstop, a bullet fired from a pistol horizontally, travels much further than normal target distances. It can easily penetrate wood or plasterboard walls or even a car door.
2. Perform basic function check (see Function check, Pg. 30) and ensure the barrel is free of obstructions.
3. Insure and check that you have the correct ammunition for the pistol.
4. Be sure that your hands and all parts of your body are kept away from the muzzle of the pistol and the slide's path.
5. Always wear eye and ear protection when firing the pistol.

### Firing procedure:

1. Point the pistol at the intended target with your finger still resting on the frame.
2. Properly align the sights and acquire correct sight picture (see Figure 13).
3. Gently put the finger on the trigger at this time and slow down or pause breathing shortly while aiming.
4. Gradually press the trigger straight to the rear while keeping the sights aligned and on target.
5. Practice good follow-through after the shot breaks by maintaining sight picture and trigger pressure "throughout" the shot.
6. Keep pistol aimed at the target and continue to fire (repeat steps 2-4) as required or until the pistol is empty. Remove the finger from the trigger and rest it on the frame if you are not manipulating the trigger for the next shot or if the pistol is lowered or not pointing directly at the target.



**WARNING:** The slide moves backward and returns forward quickly during firing. Keep your face and hands away from its path. Hot brass and powder gas is ejected quickly and can burn you. Always wear safety glasses and hearing protectors.

**NOTE:** If the hammer is cocked, the ARES *zero 1* will fire in single-action mode when trigger is depressed and if the hammer is uncocked, pressing the trigger will both cock the hammer and release it, firing the pistol in double-action mode. After the first shot has been fired in either single- or double-action mode, the ARES *zero 1* operates in a single-action trigger mode for all subsequent shots with recoiling slide cocking the hammer after each shot. Figure 16 shows comparison of the cocked and uncocked hammer positions.



Figure 15  
Two-handed grip

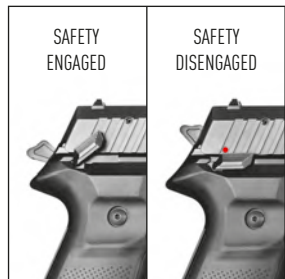

Figure 16  
Hammer cocked / uncocked

## UNLOADING

The slide catch locks the slide open after the last round is fired if there are no more cartridges in the magazine. The spring loaded magazine follower of an empty magazine pushes up on the tab located inside the magazine well. This pivots the slide catch upwards, so that it engages a cut-out on the bottom of the slide, locking it to the rear after the last cartridge case is ejected. If the slide is retracted manually with an empty magazine inserted, the slide will remain locked open.



**WARNING:** Do not rely on the slide position to determine whether the magazine is empty or not. Always check visually and physically to ensure the pistol is not loaded.

With slide locked back, the empty magazine can be removed by depressing either left or right magazine release button and visual or physical inspection of the chamber can be performed.



**WARNING:** Removing the magazine from the pistol does not prevent it from being fired! When there is a cartridge in the chamber, the manual safety disengaged and the trigger is pressed, the pistol will fire.

When the operator wishes to stop firing and unload the firearm before the last round is fired, the standard clearing procedure for the REX *zero 1* is to be employed:

1. **Point the muzzle in a safe direction and keep the fingers off the trigger** and outside of the trigger guard at all times during clearing.
2. **Remove the magazine** by depressing the magazine release button on either side and remove the magazine from the magazine well.
3. **Retract the slide fully to the rear twice**, watch for an ejected cartridge on the first retraction and hold it back on the second.
4. **Check the chamber and magazine well** for the presence of a cartridge and/or magazine visually or physically and remove if either is present.

**NOTE:** The slide can be held to the rear or locked open by pushing upwards on the slide catch-release/decocking lever for the purpose of inspection. Clearing procedure is explained in detail on Pg. 14.



Figure 17  
Remove the magazine



Figure 18  
Briskly retract slide once:  
watch for ejected cartridge



Figure 19  
Retract and hold slide back  
again: verify empty chamber

## MALFUNCTION PROCEDURES

A stoppage (i.e. malfunction or “jam”) has occurred if:

- A cartridge fails to chamber (slide is out of battery)
- A cartridge fails to ignite
- A fired cartridge case fails to extract and/or eject from the pistol
- Unburned grains of propellant powder are present in the pistol
- A shot sounds or feels weak or abnormal



**WARNING:** If the pistol failed to fire upon pressing the trigger - STOP! A live cartridge may be present in the chamber! Keep the pistol pointed in a safe direction, remove your finger from the trigger, wait 30 seconds and CLEAR the pistol.

**NOTE:** A so called “hang fire” occurs when you press the trigger and it takes several seconds for a faulty round to fire. The pistol fires eventually, but there is a delay between the time when the firing pin hits the primer and when the cartridge ignites. This may take several seconds. Do not turn the handgun away from the target and wait for at least 30 seconds to see if the round fires with delay before clearing the pistol.



**WARNING:** If you hear a weak “pop” sound and/or feel or observe reduced or no recoil during firing - STOP! A bullet may be lodged in the barrel! Keep the pistol pointed in a safe direction, remove your finger from the trigger, CLEAR the pistol and disassemble it to verify the barrel is clear of any obstructions.

**NOTE:** A so called “squib load”, is a faulty round failing to propel the bullet out the barrel. An alert operator should be able to realize this occurrence and not attempt to load or fire another cartridge. If a bullet is stuck in the bore, never attempt to shoot it out by using another cartridge, a blank or a cartridge from which the bullet has been removed. This can generate excessive pressure, damage the firearm and cause serious personal injury or death.

To rectify a malfunction, follow the clearing procedure:

1. Keep the pistol pointed in a safe direction while removing your finger from the trigger.
2. Remove the magazine from the magazine well, pulling it out if necessary.
3. Fully retract the slide several times if necessary to remove any cartridge or cartridge case from the chamber. Inspect the chamber and ejection port area for a cartridge or spent case and remove if either is present.
4. If you suspect a bullet remained in the bore, disassemble your pistol and check whether the barrel is blocked. If there is a bullet lodged in the bore, do not try to remove it yourself if you are not familiar with the proper procedures, take the pistol to a qualified gunsmith or return the pistol to your local Arax distributor (see details on the back cover).
5. If the pistol is clear and there is no obstruction in the barrel, you may reload the pistol to resume firing or secure it if you do not intend to fire at that time.

**NOTE:** The magazine floorplate and the bottom of the grip panels were purposely designed to allow the magazine to be grasped and pulled out of the pistol.

**NOTE:** There are other efficient procedures that can be followed when clearing malfunctions. Any malfunction clearing method not described herein should only be attempted with appropriate training and understanding of the specific firearm, its state and inherent risks.

## STORAGE AND TRANSPORT

1. Store and transport the pistol without any cartridges in the chamber or in the inserted magazine, or in the place of storage/transport container.
2. Store and transport the pistol with the slide forward and the hammer down (uncocked).
3. Store or transport the pistol and its components clean and lubricated.
4. Clean and lubricate the pistol and its components at least every twelve (12) months during storage.
5. Store the pistol and its components in a clean, dry, dust-free environment with stable room temperature.
6. Store the pistol and ammunition separately and securely locked.

## SELECTION AND USE OF A HOLSTER



**WARNING:** The pistol must never be returned to the holster unless proper procedures have been followed or injury or death could occur.

When putting the AREX *zero 1* pistol into the holster (i.e. holstering) the pistol must be "SAFE" or "CLEAR". The pistol is considered safe to return it to the holster when:

- fingers are off of the trigger and out of the trigger guard
- AND
- the pistol is "SAFE" - hammer down (uncocked) or manual safety "on safe" (in uppermost position)
- OR
- the pistol is "CLEAR" - no magazine or rounds present inside the firearm (see Clearing, Pg.14)

Selection - When selecting a carrying holster for the AREX *zero 1* pistol, it is important to consider the following points:

1. The holster must not make contact with trigger or actuate any of the operating controls during holstering/unholstering or during carry. This includes the slide catch-release/decocker, magazine release buttons and ambidextrous safety levers.
2. The holster must not cause the slide to move back/unlock when the pistol is holstered.
3. If the pistol is equipped with an accessory mounted on the dustcover this must be taken into account when selecting a holster.
4. If possible, choose a holster designed specifically for the AREX *zero 1* pistol. A list of manufacturers that make adequate holsters will be available at the Arex website or by contacting your local Arex distributor (see details on the back cover).

**NOTE:** Electroless nickel plating (optional on select models) provides good corrosion and wear resistance as well as superior lubricity on metal to metal contact. It is however not as tough as our nitro-carburized finish, so rough handling or improper transport might result in scratches and damage to the finish.



## SECTION 6

### DISASSEMBLY & ASSEMBLY

#### DISASSEMBLY

The level of user disassembly described herein (also referred to as "field stripping") is sufficient to allow for proper cleaning & maintenance of the AREX *zero 1* pistol. Further disassembly should only be done by a qualified gunsmith or certified Arex armorers.



**WARNING:** Before attempting to disassemble the AREX *zero 1* pistol, make sure it is completely unloaded - clear. This includes the magazine and chamber.

1. Clear the AREX *zero 1* (see Clearing, Pg.14)!
2. With the slide locked (or held) to the rear (see Figure 20) and the magazine removed, rotate the disassembly lever, located on the left hand side of the frame, clockwise until the lever is pointing downwards (see Figure 21).

**NOTE:** The disassembly lever is easier to rotate when the slide is held manually to the rear, thus relieving the slide stop of the recoil spring pressure. The lever should be held at approximately seven o'clock position in order to clear the slide during its removal (see Figure 22).

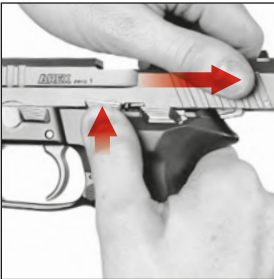

Figure 20 — locking the slide



Figure 21 — Rotating the disassembly lever

3. Pull the slide slightly rearward so that slide catch disengages and ease the slide forward, removing the slide with barrel and recoil spring assembly from the frame (see Figure 22).



**WARNING:** Slide is under recoil spring tension. Maintain control during slide removal to prevent injury. Wear eye protection.



Figure 22 — Removing the slide from the frame by sliding it forward

4. Turn the slide upside down and carefully push the recoil spring guide forward a few millimeters and carefully lift it out of slide along with the recoil spring - do not let go until the recoil spring is fully extended and clear of the slide (see Figure 23).



**WARNING:** The recoil spring and guide are under spring tension and not firmly attached to the slide. If released prematurely, these parts can be expelled from the pistol causing injury or damage. Point the recoil spring guide away from the face and eyes. Wear eye protection.



Figure 23 — Removing the recoil spring assembly. Caution: spring under tension!

5. With the slide still upside down, take the barrel out of the slide by pushing up on the rear portion of the barrel through the ejection port, lifting it out, and separating it from the slide.

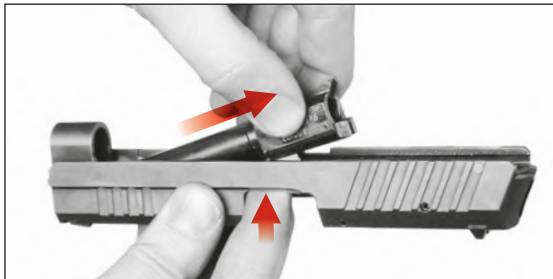

Figure 24 — Removing the barrel from the slide by lifting it up



**WARNING:** Do not attempt to disassemble your pistol beyond the point explained in this manual.

## MAGAZINE DISASSEMBLY



**CAUTION:** Be aware the magazine spring is under tension when removing and installing the magazine floorplate. Keep the base of the magazine pointed away from the face and eyes at all times during disassembly and reassembly. Wear eye protection.

### Disassembly of regular-capacity magazines

1. Using a blunt, pointed instrument, depress the locking detent through the hole located in the floorplate and hold it there (see Figure 25).
2. Place a portion of either hand over the base of the magazine to control the release of the magazine spring and locking plate (see Figure 26).
3. Slowly slide the floorplate forward off the magazine housing.
4. Gradually allow the locking plate and magazine spring to expand out of the magazine housing (see Figure 27).
5. Remove the locking plate, magazine spring and magazine follower from the magazine housing.

**NOTE:** This level of disassembly is sufficient to allow a thorough cleaning of the magazine components.



Figure 25  
Depressing locking detent in floorplate

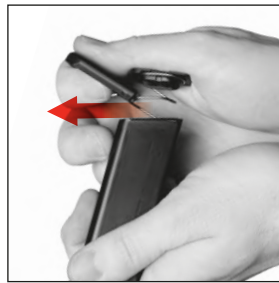

Figure 26  
Sliding the floorplate forward  
Caution: spring under tension!

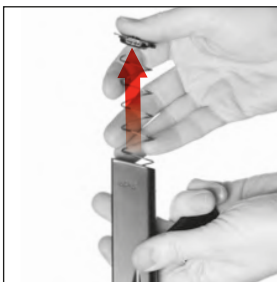

Figure 27  
Removing the locking plate with spring and follower



Figure 28  
17-round (US) and 18-round (EU) magazine components

## ASSEMBLY

1. Turn the slide upside down and insert the barrel into the slide, muzzle first, with the flat side of the enlarged back portion facing downwards until it seats into the slide's ejection port.
2. Insert the exposed end of the recoil spring into the opening in front of the slide, below the barrel.
3. Push the guide and the recoil spring forward into position, carefully compressing the recoil spring and positioning the back of the recoil spring guide in front of the barrel's guiding lug (see Figure 29).



**WARNING:** The recoil spring and guide are brought under tension in this process. If released prematurely, these parts can be expelled from the pistol causing injury or damage. Point the recoil spring guide away from the face and eyes. Wear eye protection.

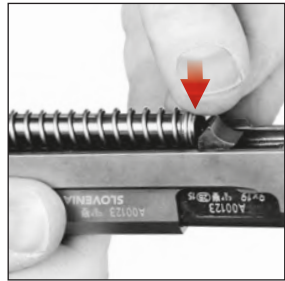

Figure 29 — Reassembling the recoil spring onto the barrel and slide  
(wide end of the spring guide located in front of barrel's guiding lug)

4. Ensure that NO magazine is present in the magazine well and that the disassembly lever is in the down position.
5. Mount the slide onto the frame, ensuring that the recoil spring is centered underneath the barrel and aligning the slide and frame guides (see Figure 30).

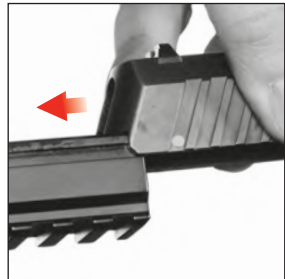

Figure 30 — Mounting the slide on the frame  
(frame guides aligned with slide grooves)

6. Pull the slide back towards its rearmost position and hold it there or push up on slide catch-release lever thus locking the slide back.

7. Pivot the disassembly lever counter clockwise to its horizontal position - parallel to the bottom of the slide (see Figure 31). Pull the slide slightly rearward so that slide catch disengages and ease the slide forward.



Figure 31 — Pivot the disassembly lever counter clockwise

### MAGAZINE ASSEMBLY

Start at step 3 if the magazine follower and the locking plate are already attached to the spring.

1. Place the magazine spring in the magazine follower so the hook at the narrower end of the spring snaps in the hole at the bottom of the follower from left side (front of the follower points up).

2. Place the locking plate onto the wider end of the magazine spring so that the rounded corners face toward the front of the magazine and let it snap in place.

3. Insert the follower and magazine spring into the magazine housing (see Figure 32).

4. Push the locking plate into the magazine housing against the pressure of the magazine spring and hold it there while sliding the floorplate all the way onto the guides until the locking plate detent locks into the floorplate (see Figure 33).

Finally, check the magazine for proper function by insuring that the follower slides up and down within the magazine housing freely under spring tension. Also, check that the magazine follower rests at the top of the magazine housing, with its highest edge almost in line with the magazine feed lips.



Figure 32  
Insert the follower, spring,  
and locking plate



Figure 33  
Hold the locking plate  
in the magazine body  
while sliding the floorplate  
onto guides until  
detent clicks in place



**WARNING:** The magazine spring is brought under tension in this process. If released prematurely, it can be expelled from the magazine body causing injury or damage. Point it away from the face and eyes. Wear eye protection.

## FUNCTION CHECK

It is essential that a basic function check be performed on the AREX *zero 1* every time after assembly to ensure that the firearm's components have been installed correctly. Below sequence is not random but can be changed if operator knows and understands the pistol's functions.

1. **Clear the AREX *zero 1*** (see Clearing, Pg.14)!
2. **Slide action** - Ensuring that fingers are off the trigger and outside the trigger guard, rack the slide (pulling it briskly to its rearmost position and releasing) three or four times. The slide should be able to glide smoothly back and snap forward, under the tension of the recoil spring, without binding or locking up.
3. **Hammer cocking** - Return the slide to battery and check the hammer - it should be cocked.
4. **Single-action trigger** - Keeping the unloaded pistol pointed in a safe direction, press the trigger of the AREX *zero 1* - hammer should fall and rebound away from the firing pin slightly (single-action mode). Keep the trigger fully depressed and try to push on the hammer from behind - it should move forward touching the firing pin.
5. **Disconnecter function** - While maintaining backward pressure on the trigger, rack the slide to the rear and release it, holding the trigger to the back, until the slide returns to battery. Release the trigger - it should reset (audible and felt "click") after moving forward 4 mm - the hammer should remain cocked.
6. **Slide catch-release function** - Insert an empty magazine in the magazine well and rack the slide to rear. The slide should lock open with an empty magazine inserted. Depress the magazine release button (left or right) and remove the magazine from the pistol. Push down on the slide catch-release/decocking lever. The slide should snap forward and return to battery (close completely).
7. **Manual safety function (cocked)** - Engage the safety (i.e. push the safety lever to its upper position) and press the trigger. The trigger should move freely and hammer should remain cocked.
8. **Decocking lever function** - Push down on the slide catch-release/decocking lever to decock the hammer. The hammer should fall (even with manual safety "on safe"), but stop before touching the firing pin and remain in the safety stand-off position even if pushed from behind (hammer safety stand-off function).
9. **Manual safety function (decocked)** Disengage the safety (i.e. push the safety lever to its lower position), then reengage it (i.e. put the safety back "on safe") and press the trigger. The trigger should move freely and hammer should remain uncocked.
10. **Double-action trigger** - Disengage the safety and keeping the unloaded pistol pointed in a safe direction, press the trigger of the AREX *zero 1* - hammer should cock and fall, rebounding away from the firing pin slightly (double-action mode). The trigger should return to its forward position when released.



**WARNING:** Never use a firearm that shows signs of damage or fails a function check. If the condition or function of the pistol or magazine is suspect, return the pistol or magazine to your local Arex distributor (see details on the back cover).

Contact your local Arex distributor (see details on the back cover) or Arex Customer Service Department by email: [info@arex.si](mailto:info@arex.si) if you encounter any problems attempting to disassemble, assemble, and/or conduct a function check on the AREX *zero 1* pistol.

## CLEANING &amp; MAINTENANCE

## CLEANING

NOTE: The service life and performance of your AREX zero 1 pistol is dependent upon proper care and maintenance.

Materials Required - we suggest you use at least the following cleaning set and materials to properly clean the AREX zero 1 pistol:

- Appropriate cleaning rod with handle
- Patch holder
- Nylon bore brush (in the appropriate caliber)
- Bronze bore brush (in the appropriate caliber)
- Cotton bore mop
- Nylon brush
- Cleaning patches
- Lint-free wiping rag
- Cleaning solvent/lubricant

Cleaning Intervals - Regular and Extensive are the two types of operator cleaning for the AREX zero 1 pistol.

Regular Cleaning - Performed after each firing or every twelve (12) months.

Extensive Cleaning - Often referred to as "detailed cleaning." Performed after the firing of 500 cartridges or when the pistol has been exposed to or immersed in sand, dust, water (especially seawater) or other foreign contaminants.



**WARNING:** Wear eye protection and follow other precautions stipulated by the manufacturer when using cleaning solvents/lubricants.



**CAUTION:** Never use a stainless steel bore brush to avoid scratching the bore thus reducing accuracy. If the cleaning solvent is not safe for the skin, it is not recommended for use with the AREX zero1 pistol.

### Regular Cleaning Barrel

- Saturate the bronze or nylon bore brush with solvent and push it through the bore from chamber to muzzle one or two passes, one direction preferably.
- After applying the solvent, set the barrel aside while cleaning slide and frame.
- After leaving the solvent in the bore for 5-10 minutes, run the bronze or nylon bore brush through the bore from chamber to muzzle at least five passes, one direction preferably, to remove any fouling.
- Use patch holder to run cleaning patches through the bore from chamber to muzzle, removing fouling or solvent residue. Change the patches until a clean one emerges from the muzzle end of the barrel.
- Moisten the cotton bore mop with lubricant and run it through the barrel to apply a thin oil film.
- Brush or wipe the exterior of the barrel with the nylon brush and rag moistened with solvent to remove fouling.

## Slide

- Gently brush all internal surfaces of the slide using the nylon brush moistened with solvent.
- Remove all surface fouling from internal and external surfaces of the slide using a rag.

## Recoil spring assembly

- Remove all visible fouling using solvent and a nylon brush or a rag.

## Frame

- Scrub all visible internal surfaces where carbon fouling is present using the nylon brush moistened with solvent.
- Using a rag and cleaning patches, remove all fouling from accessible internal and all external surfaces of the frame.

## Magazine

- Scrub the magazine follower and feed lips, using the nylon brush moistened with solvent.
- Using a rag, remove all fouling from all external surfaces of the magazine.

## Extensive Cleaning

Extensive cleaning is the same as regular cleaning except that:

- The magazine is disassembled for cleaning.
- All parts should be either rinsed with or completely immersed in cleaning solvent and thoroughly scrubbed with a nylon brush. Compressed air should then be used to remove the loose fouling/contaminants and excess solvent and to dry all assemblies and components.

NOTE: The AREX *zero 1* pistol can be cleaned using an ultrasonic cleaning solution. However, the use of ultrasonic cleaning can result in the unwanted removal of colored safety reference markings on the slide. Use of ultrasonic cleaning is normally neither necessary nor recommended when using standard factory ammunition. All components must be thoroughly dried and properly lubricated after being immersed in solvents or cleaning solutions of any kind before reassembly. For additional cleaning recommendations after use in extreme environments, please contact your local Arex distributor (see details on the back cover) or Arex Customer Service Department by email: [info@arex.si](mailto:info@arex.si)

## INSPECTION

During and after cleaning, visually inspect the pistol and its components for any irregularities that may cause problems or stoppages/jams during operation. Generally, you should always keep an eye on any of the discrepancies listed below.

 **WARNING:** Always clear the pistol before conducting an inspection!

### Check for:

- Damaged or missing parts
- Improper assembly or function
- Absence of free movement, where expected
- Absence of spring tension, where expected
- Unexpected tolerances, movement and looseness
- Parts exhibiting signs of cracks, burrs, dents or obvious signs of damage or stress
- Lack of stops or tactile clicks, where expected
- General overall cleanliness
- Presence of inadequate or heavy lubrication
- Presence of corrosion or degradation of surfaces.





**CAUTION:** The AREX *zero 1* was designed to achieve optimal safety, speed and accuracy in a dependable and durable pistol. Do not try to “improve” the pistol by altering any of its components. Altering any part of the AREX *zero 1* or its magazines may cause serious injury or death and will void manufacturer’s warranty on the product.

## LUBRICATION

Metal surfaces of the AREX *zero 1* pistol are treated with advanced corrosion and wear-resistant finishes. This does not mean that it is maintenance free. It is imperative to properly lubricate the pistol to achieve reduced friction between interacting surfaces and ensure proper functioning. Any type of high-quality oil, specifically designed for use on firearms will work well on the AREX *zero 1*. Do not use lubricants that claim to be able to “creep” or penetrate metal as these substances may incapacitate primers in ammunition. Figure 34 shows areas on the pistol requiring particular attention to lubrication.



Figure 34 — Medium lubrication points marked red (view of the slide underside)

### Where and How Much

No lubrication (surface feels dry and is not slippery to the touch).

- All plastic components
- Ammunition
- Sights
- All external operating levers
- External accessories (e.g. lights, lasers)

Light lubrication (surface lubrication is visible but feels only slightly lubricated to the touch).

- Bore, chamber and exterior of barrel
- All metal parts
- All internal parts in slide and frame
- Magazine spring
- Recoil spring assembly
- Magazine housing

Medium lubrication (surface feels slippery to the touch, but oil does not run down vertically held surfaces).

- The enlarged rear portion of the barrel: stepped forward edge and guiding lug
- Barrel unlocking block in the frame
- Slide grooves and frame guides
- Extractor
- Trigger axle, firing mechanism

Heavy lubrication (oil runs down the surface when it is held in a vertical position).

No heavy lubrication is required on the AREX *zero 1* pistols.

Re-apply lubricant periodically after firing as the heat will evaporate it. Apply lubricant using clean cotton swabs, patches or rag. A spray bottle of lubricant may also be used directly when compressed air is used afterwards to circulate the lubricant into all parts and to remove the excess from the pistol.

## TROUBLESHOOTING PROBLEMS AND REPAIR

Common causes of problems that are often overlooked include:

- Fouled, unlubricated or improperly lubricated pistol
- Bad ammunition
- Damaged magazines
- Operator error.

MALFUNCTION	CAUSE	CORRECTION
<b>FEED</b>		
No round fed into the chamber	Magazine not properly inserted	Insert magazine properly
	Magazine is deformed or dirty	Replace magazine
	Incorrect or defective ammunition	Inspect and replace ammunition
Slide does not close easily or completely	Pistol or cartridge is fouled (dirty) or pistol is too heavily lubricated	Clean and lubricate pistol and/or replace the ammunition
	Incorrect ammunition	Replace ammunition
	Pistol requires service	Return to your local Arex distributor
<b>IGNITION</b>		
Hammer drops but round does not fire	Faulty ammunition	Press the trigger again or rack the slide to cycle next round
	Firing pin obstructed	Pistol requires cleaning/service
	Pistol requires service	Return to your local Arex distributor
<b>EXTRACTION/EJECTION</b>		
After firing, the case stays in the chamber or is jammed in the ejection port	Insufficient recoil due to dirt	Clean and lubricate the pistol
	Slide movement is slowed /blocked by the firing grip	Correct firing grip
	Light hold or limp wrist	Apply solid grip, rigid hold
	Low-powered ammunition	Change ammunition
	Fouling in the extractor area	Clean the extractor area
	Damaged or broken extractor	Replace, pistol requires service
Pistol requires service	Return to your local Arex distributor	

## SERVICE POLICY

If your AREX zero 1 pistol still fails to function after applying malfunction procedures (see Pg. 23) and troubleshooting problems (see above table), please contact your local Arex distributor (see details on the back cover) or Arex Customer Service Department by email: info@arex.si for the name and address of your nearest Authorized Repair Facility. Law enforcement users, contact your unit armorer or local Arex distributor (see details on the back cover).

## WARRANTY REGISTRATION

New AREX firearms are covered by Arex's Limited Lifetime Warranty. To inquire about warranty registration, please contact your local Arex distributor (see details on the back cover) or Arex Customer Service Department by email: info@arex.si

AREX *zero 1 Tactical* (model specific information)Figure T1 - AREX *zero 1 Tactical* with installed reflex optical sight.Figure T2 - AREX *zero 1 Tactical* extended barrel with thread protector removed

## DIMENSIONS &amp; WEIGHT

Length OA	212 mm 8,1 in
Barrel Length	126 mm 4,9 in
Height (without magazine)	150 mm 5,9 in
Weight (without magazine)	856 g (2 lbs) 30 oz

(specs not shown correspond with the standard model)

## EXTENDED AND THREADED BARREL

The extended cold hammer forged barrel provides the AREX *zero 1 Tactical* with a higher level of accuracy and an additional mounting interface. The barrel is threaded with threads (M13,5 x1 LH) in order to accept only accessories specifically designed for the AREX *zero 1* pistol. Any barrel accessory might negatively affect reliability of the pistol and should be thoroughly tested in order to verify the contrary. Only appropriate, fully jacketed subsonic ammunition should be used with suppressor attached. Thread protector is provided for whenever the AREX *zero 1 Tactical* is to be used without barrel attachments.



**WARNING:** Always clear the AREX *zero 1 Tactical* pistol before installing or removing accessories [see Clearing, Pg. 14].

**NOTE:** thread protector is knurled to facilitate mounting and removal and a flat surface for tightening/loosening with a standard 15 mm fork wrench is provided.



**CAUTION:** Never attach a barrel accessory that was not designed and approved for the use on the AREX *zero 1 Tactical* by Arex. Doing so will void manufacturer's warranty on the product and can result in serious injury, damage to property and death. Extensive use of a compensator or suppressor with high velocity ammunition will negatively influence the service life expectancy of the pistol.

## SUPPRESSOR HEIGHT SIGHTS

AREX *zero 1 Tactical* is fitted with high profile front and rear sights equipped with white inserts. The sights will clear dedicated suppressors and allow for normal aiming with the pistol when this optional equipment is mounted to the barrel. Higher profile of the sights will also enable co-witnessing with most reflex optical sights.



Figure T3 - Co-witnessing of reflex optical sight with high profile 3-dot sights



Figure T4- Mount the reflex optical sight according to manufacturer's instructions

NOTE: Three different heights of the raised front sight are available to correct the elevation of the point of impact. Windage is to be adjusted by drifting the front sight primarily and rear sight secondarily. Sights should only be exchanged and/or adjusted by a qualified gunsmith or certified Arex armorer.



**WARNING:** Always clear the AREX *zero 1 Tactical* pistol before attempting to adjust or replace sights (see Clearing, Pg. 14).

## AOR PLATFORM

AREX *zero 1 Tactical* is factory equipped with an universal reflex optics platform (Arex Optics Ready) - a special recess milled into the slide. Four standardized interface plates are included to provide secure and low profile mounting platform for most proven miniature reflex sights ("red dots").

Specific AOR (Arex Optics Ready) interface plates accommodate the following reflex optical sights:

- Trijicon (RMR)
- C-More (RTS, STS), Vortex (Razor)
- Shield (SMS, RMS), JPoint (MRD)
- Docter (Sight), Meopta (MeoSight), Vortex (Viper, Venom), Eotech & Insight (MRDS), Burris (FastFire)

NOTE: The AOR interface plates are marked with the names of the manufacturers whose sights have been tested with the AREX *zero 1 Tactical* pistol. Insure that the reflex sight you intend to mount on the pistol fits one of the plates and that appropriate plate is selected for mounting (see the above list and markings on the AOR plates).

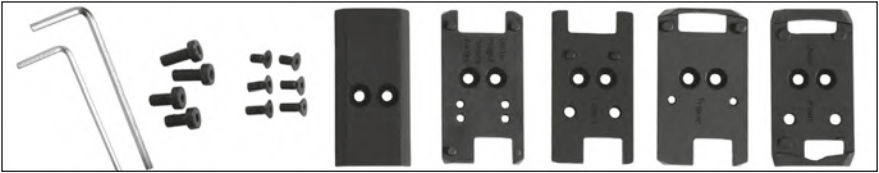

Figure T5 - AOR interface plates, cover plate and included mounting hardware

The AOR platform set includes three pairs of M3 screws with countersunk Allen (hex) socket heads in three lengths with appropriate Allen key (2,5 mm) for mounting the interface plates and specific optical sights. Also included are two pairs of flat Allen socket head M4 screws in two lengths with appropriate Allen key (3 mm) for mounting specific optics.

To mount a chosen reflex optic ("red dot") onto the AREX *zero 1 Tactical* slide, first clear the firearm. Remove the AOR cover plate secured in place with two M3 screws (use the included 2,5 mm Allen key).



Figure T6 - Removing the Arex Optics Ready cover plate



Figure T7 - Mounting the appropriate interface plate

Choose the applicable AOR interface plate (depending on the reflex sight to be mounted) and place it on the slide orienting it correctly. Choose the appropriate length of the countersunk head screws and apply a small amount of non-permanent thread locking compound (such as Loctite 243) to threads only (barely covering the threads). Tighten the screws to fix the AOR interface plate to the slide of the AREX *zero 1 Tactical*. Do not overtighten. Tighten to 2 Nm (12 in-lb) using a torque wrench or hand tighten by inserting the short end of the provided Allen key into the socket head then turning it till slight flex is felt in the key. With the AOR interface plate mounted correctly you can proceed with installation of the specific reflex sight according to the directions of the sight manufacturer.

**WARNING:** It is the owner's responsibility to be absolutely certain that any chosen optical sight fits and is installed properly. Improper installment of an accessory may result in a dangerous malfunction, damage to the firearm, and serious injury to the shooter and other persons. The owner of the pistol and installer of accessories accepts full responsibility for the correct installment and functioning of the firearm after such installation.

**NOTE:** Only fire the AREX *zero 1 Tactical* with the AOR cover plate mounted or an interface plate AND reflex sight installed.

AREX *zero 1* ACCESSORIES

## RAIL MOUNTED ACCESSORIES

The AREX *zero 1* has an extended full length MIL-STD-1913 (Picatinny) interface rail machined in the dustcover (the front, lower portion of the frame). This interface allows the operator to mount a wide variety of lights, laser aimers and other accessories to the handgun by means of the simple and proven Picatinny system (see Figure 35).



Figure 35 — Accessory light and laser aiming module mounted on AREX *zero 1*



**WARNING:** Always ensure the AREX *zero 1* pistol is “clear” before installing or removing accessories.

To avoid damage to the accessory and the AREX *zero 1*, carefully follow the instructions of the manufacturer for installing, operating, and removing accessories from the mounting rails. Most lights, laser aimers, and similar accessories are installed by sliding them onto the front of the rail system while depressing a locking mechanism or clipping them on from the bottom.

**NOTE:** Weight of any frame (dust cover) mounted accessories should not exceed 11 ounces (300 grams) to ensure reliable function. The accessory might not fit correctly if it was not manufactured specifically for the MIL-STD-1913 (Picatinny) interface mounting.



Figure 36 — Installing accessory lights onto the rails

For a list of accessories that fit the AREX *zero 1* pistol, contact your local Arex distributor (see details on the back cover)



**CAUTION:** Improperly designed or installed accessories may result in damage to the rail system and/or the pistol. Such damage is not covered under warranty.

**NOTE:** If after reviewing this manual you still have questions, please contact your local Arex distributor (see details on the back cover) or Arex Customer Service Department by e-mail [info@arex.si](mailto:info@arex.si)

## SECTION 10

### PARTS LIST & EXPLODED VIEW

#### Parts Policy

Arex Customer Service Department maintains a full complement of replacement parts. Even though most gunsmiths have the knowledge, training, and the ability to make necessary repairs to your firearm, the skill and workmanship of any particular gunsmith is simply beyond our control.

NOTE: Should your firearm ever require service, we strongly recommend that you return it to your local Arex distributor (see details on the back cover, see Pg. 34 - Service Policy). The AREX zero 1 pistol is a precision instrument built to highest standards and tight tolerances so original replacement parts will generally require no fitting.

If any part is ordered without returning the firearm to Arex, the customer takes full responsibility for ensuring that the part supplied is correct for their particular firearm and is properly installed and fitted by a qualified gunsmith.

AREX d.o.o. CANNOT BE RESPONSIBLE FOR THE FUNCTIONING OF ANY FIREARM IN WHICH REPLACEMENT PARTS ARE INSTALLED BY OTHERS.



**WARNING:** It is the purchaser's responsibility to be absolutely certain that any parts ordered from the factory are correctly fitted and installed. Firearms are complicated mechanisms and improper installment of parts may result in a dangerous malfunction, damage to the firearm, and serious injury to the shooter and other persons. The purchaser and installer of parts accepts full responsibility for the correct adjustment and functioning of the firearm after such installation.

### PARTS LIST (see Pg. 37 — exploded view — Figure 37)

ITEM DESCRIPTION	CODE	ITEM DESCRIPTION	CODE	ITEM DESCRIPTION	CODE	ITEM DESCRIPTION	CODE
1 FRONT SIGHT	402 005	17 SLIDE STOP SPRING	402 017	33 TRIGGER BAR SPRING	402 032	49 MAGAZINE CATCH AXLE	501 405
2 REAR SIGHT	402 006	18 DISASSEMBLY LEVER	501 801	34 RIGHT HAND SAFETY LEVER	402 033	50 MAGAZINE CATCH SPRING	402 048
3 LOADED CHAMBER INDICATOR	402 007	19 TRIGGER BAR PIN	501 684	35 LEFT HAND SAFETY LEVER	402 034	51 MAGAZINE RELEASE BUTTON	402 049
4 LOADED CHAMBER INDICATOR AXLE	402 008	20 TRIGGER BAR	501 814	36 SAFETY LEVER PIN	402 035	52 LEFT GRIP PANEL	501 714
5 LOADED CHAMBER INDICATOR SPRING	402 009	21 SEAR AXLE	501 398	37 SAFETY LEVER INDEXING PLUNGER	501 793	53 GRIP PANEL SCREW	501 830
6 FIRING PIN	501 791	22 SPRING LIMITING PIN	402 021	38 SAFETY LEVER SPRING	402 036	54 RIGHT GRIP PANEL	501 714
7 FIRING PIN SPRING	402 010	23 SEAR	501 805	39 HAMMER SPRING	402 037	55 SLIDE CATCH DECOCKER LEVER SPRING	402 050
8 FIRING PIN BLOCK SPRING	402 011	24 SEAR SPRING	402 023	40 HAMMER STRUT	501 823	56 FRAME	402 066
9 FIRING PIN BLOCK PLUNGER	501 803	25 FIRING PIN BLOCK LEVER	501 817	41 LANYARD PIN	501 398	57 MAGAZINE HOUSING	
10 FIRING PIN EXTRACTOR LOCKING PIN	402 013	26 EJECTOR	501 820	42 TRIGGER	402 040	58 MAGAZINE FOLLOWER	
11 EXTRACTOR	501 810	27 REST	402 026	43 SLIDE STOP	501 826	59 MAGAZINE SPRING	
12 SLIDE	501 785	28 REST AXLE	501 392	44 TRIGGER AXLE	501 796	60 MAGAZINE LOCKING PLATE	
13 BARREL	501 786	29 HAMMER	402 028	45 SLIDE CATCH DECOCKER LEVER	402 043	61 MAGAZINE FLOORPLATE	
14 RECOIL SPRING GUIDE	501 798	30 HAMMER AXLE	501 794	46 SLIDE CATCH DECOCKER LEVER HOLDER	402 044	MAGAZINE COMPLETE 9X19 S 17RD	402 148
15 RECOIL SPRING	402 016	31 HAMMER STRUT PIN	501 394	47 SLIDE CATCH DECOCKER LEVER HOLDER SPRING	402 045	MAGAZINE COMPLETE 9X19 S 18RD	402 102
16 UNLOCKING BLOCK	501 790	32 REST SPRING	402 031	48 MAGAZINE CATCH	402 046		

Figure 37 — AREX zero 1 Exploded Diagram

# AREX zero 1

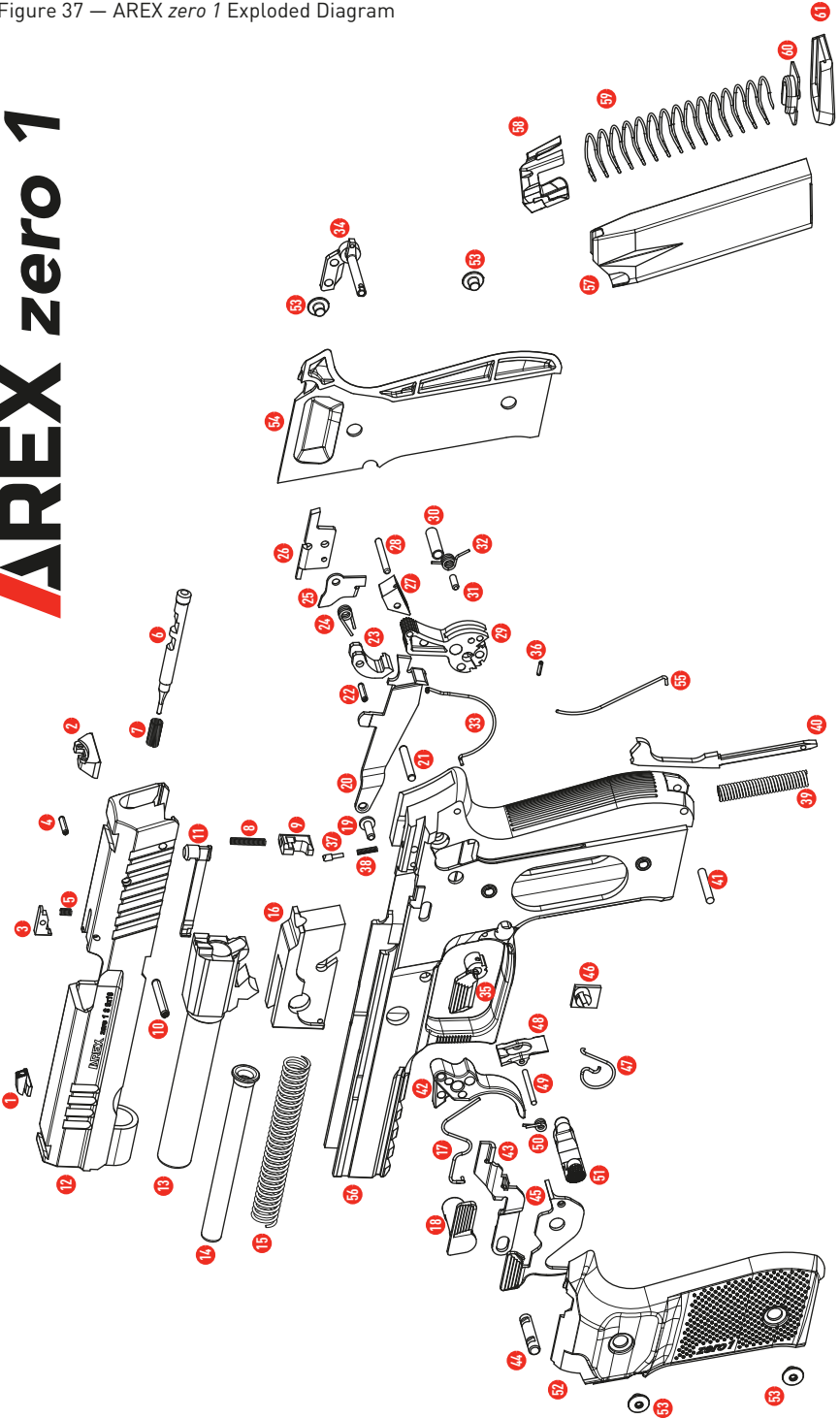



# FIREARMS SERVICE RECORD

WEAPON TYPE	SERIAL NUMBER
-------------	---------------

DATE	NUMBER OF ROUNDS FIRED	CUMULATIVE TOTAL OF ROUNDS FIRED	USER'S NAME	MAINTENANCE & REMARKS







manufactured in EU  
SLOVENIA

**AREX**

AREX d.o.o. Šentjernej  
Trubarjeva cesta 7, SI-8310 Šentjernej, Slovenia, EU  
NCAGE: 1064Q  
Phone: +386 7 393 34 50 / Fax: +386 7 393 34 51  
info@arex.si  
[www.arex.si](http://www.arex.si)